

Photonuclear & Hadron Physics Future outlook

Daniel Watts
University of Edinburgh



Scope of talk

- Forward look at future Photonuclear/Hadron Physics facilities
- Indicate the present engagement of the Glasgow and Edinburgh groups in these projects in terms of equipment R&D
- Outline (some of!) our Physics interests at the new facilities

Facilities : Medium to long Term

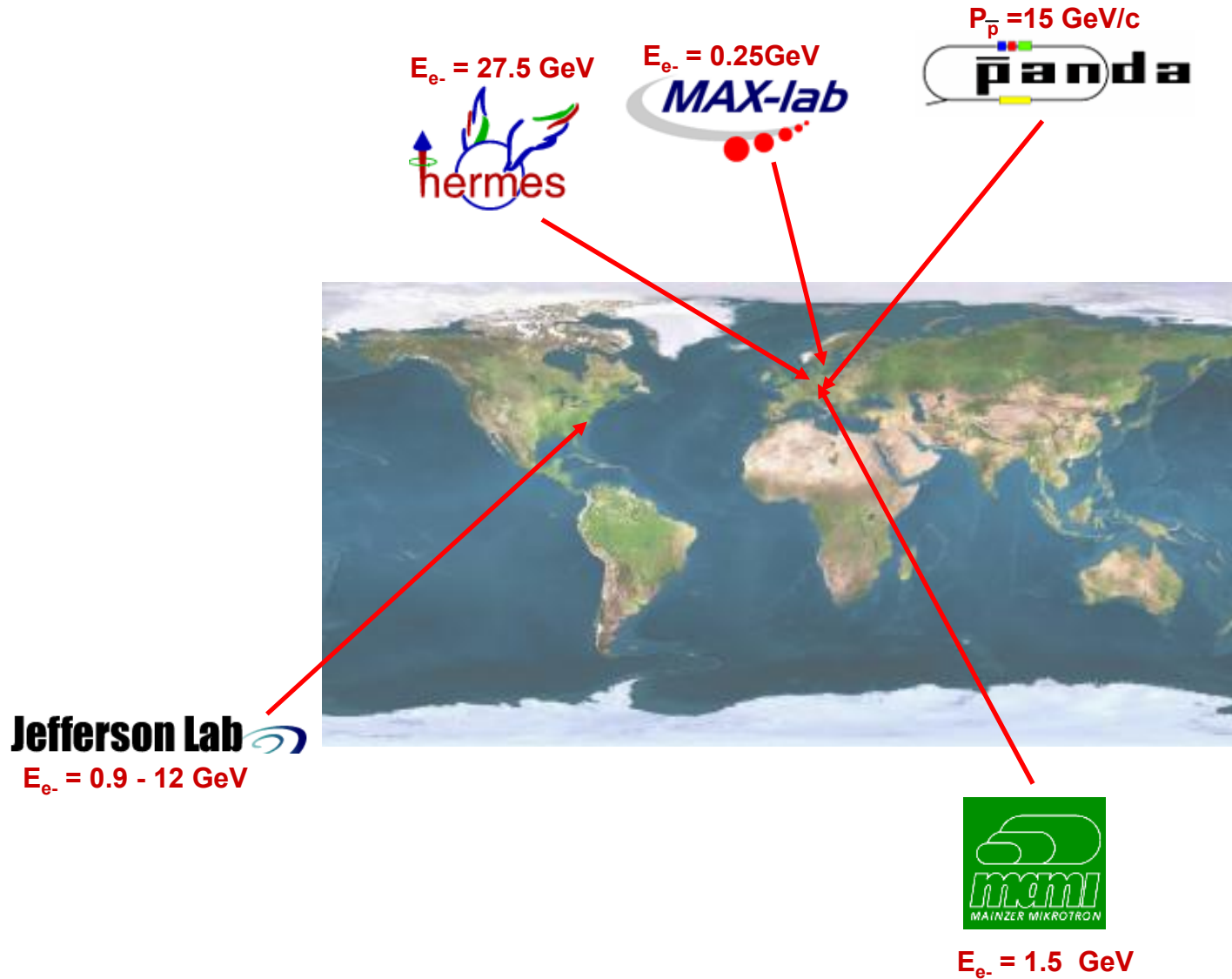

Timelines & Upgrades

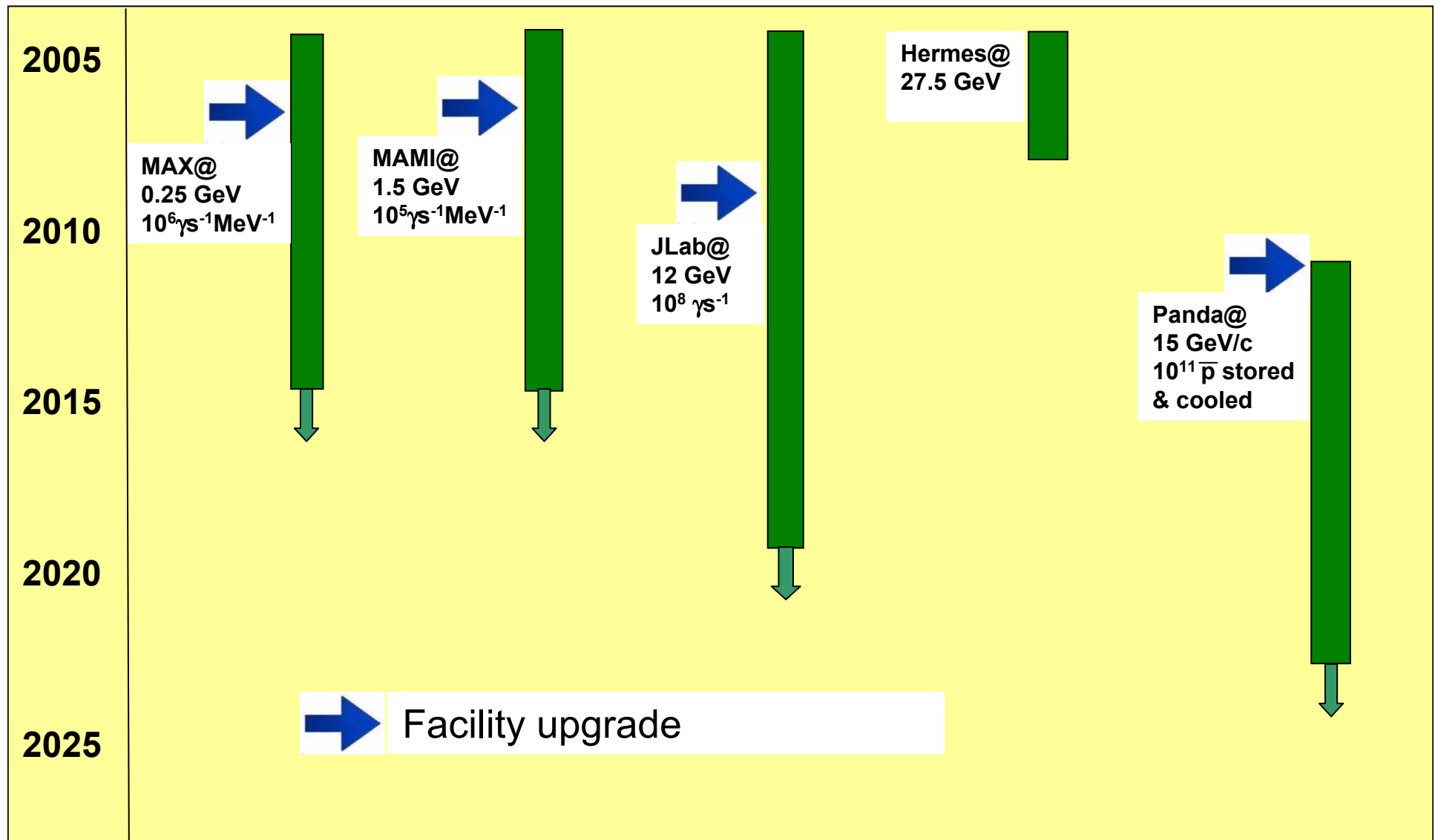
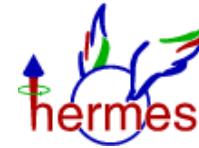

The MAMI-C facility

- 100% duty factor electron microtron
- MAMI-C 1.5 GeV upgrade (2006)
(MAMI-B 0.85 GeV)

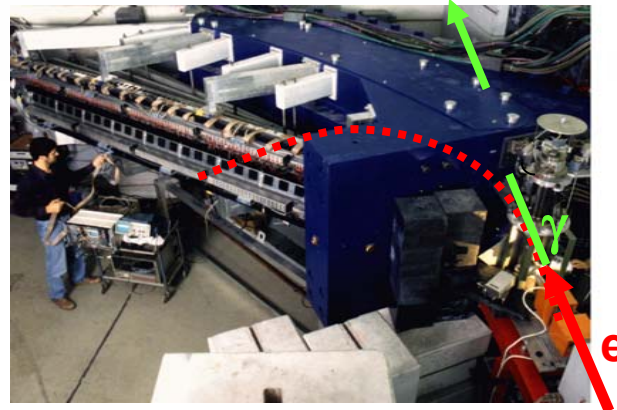
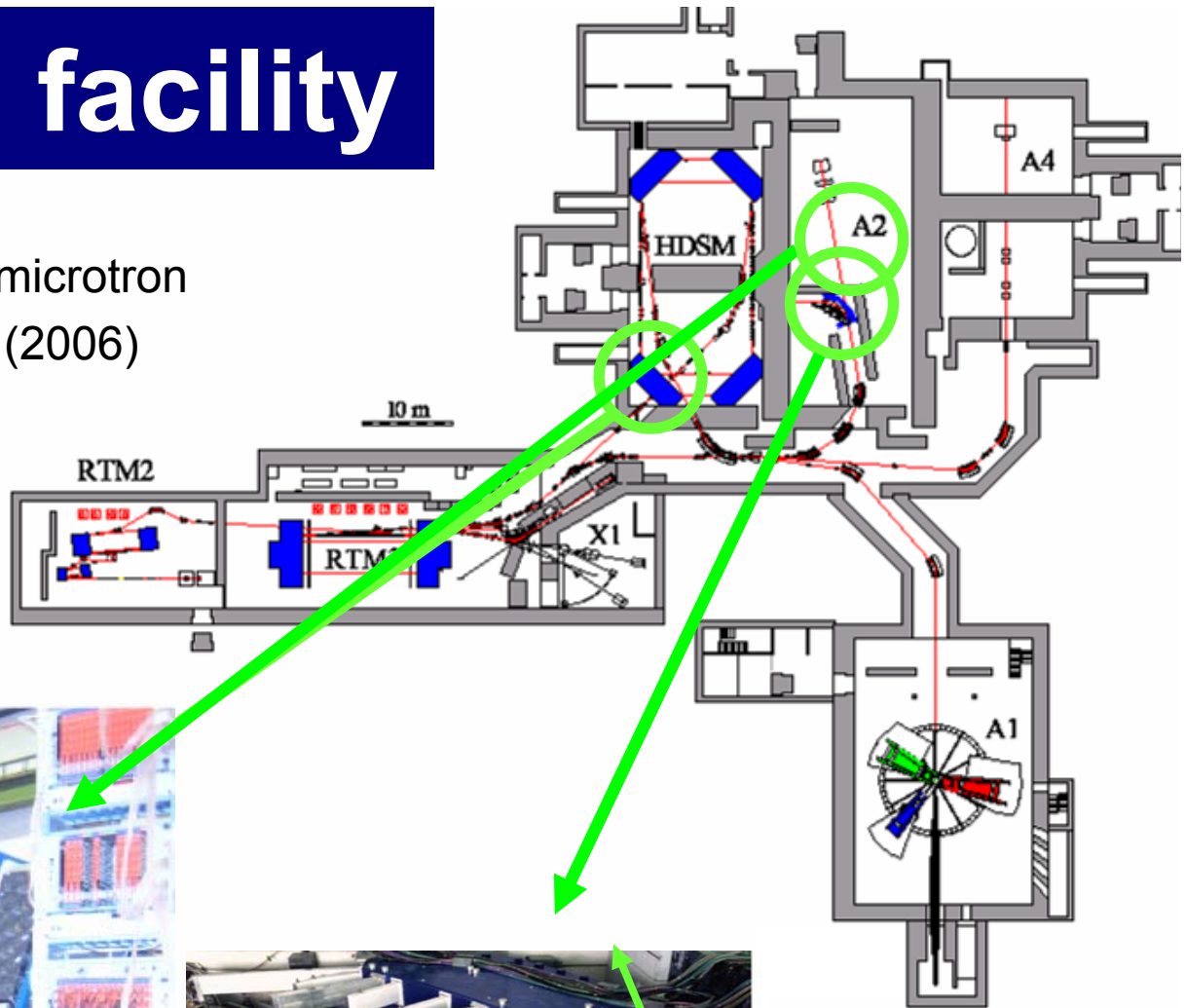

Contributions to Future facilities : MAMI-C



Upgrade of photon tagger & polarised γ (Glasgow)

Recoil Nucleon Polarimetry (Edinburgh)

Particle Identification sub-detector (Edinburgh)

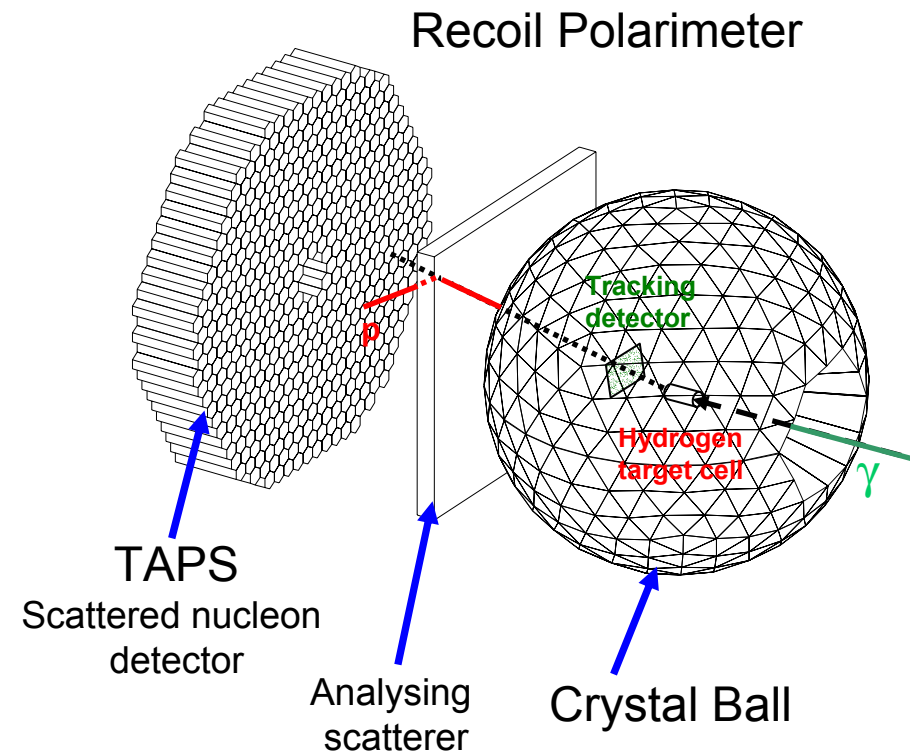
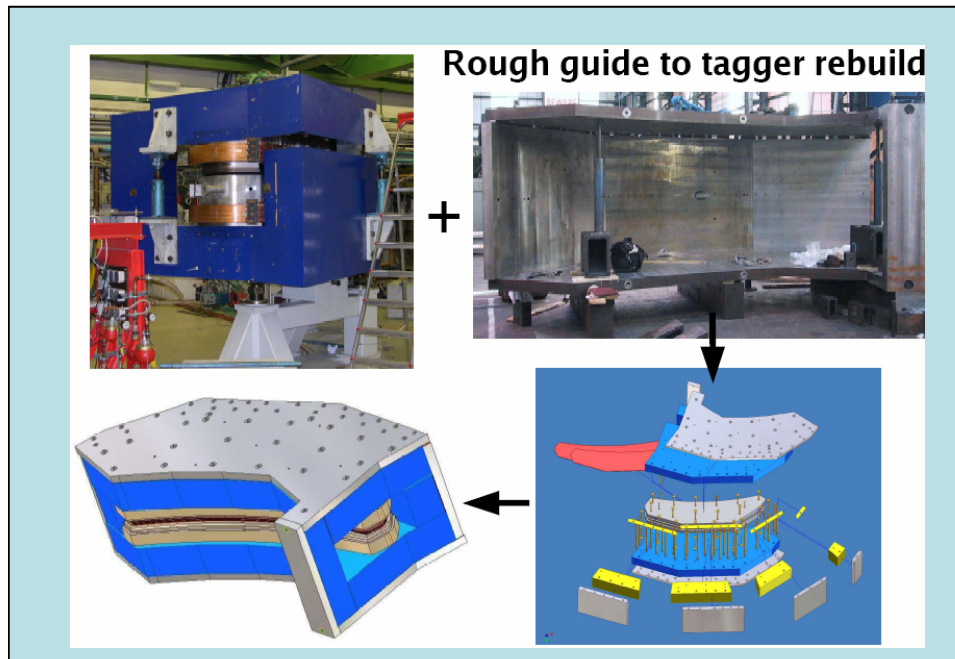

Physics : MAMI-C

- Provide “ambiguity free” information on the spectrum of nucleon resonances – **First ever complete determination of observables**

$$\vec{\gamma} + \vec{N} \rightarrow N^* \rightarrow \vec{N} + \pi$$

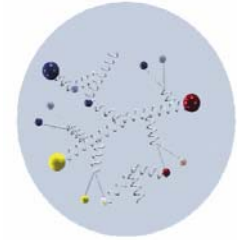
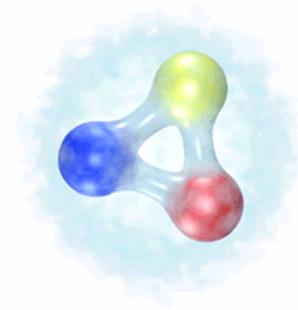

- Magnetic moments of nucleon resonances e.g. $\mu(s_{11}(1535))$
- World's leading η, η' meson production facility - Test QCD based models and C, CP, CPT invariance
- Precision Nuclear Matter form factor measurements (~ 0.05 fm accuracy)
- Use photon probe as complimentary way to access neutron rich nuclei??

JLab@12 GeV

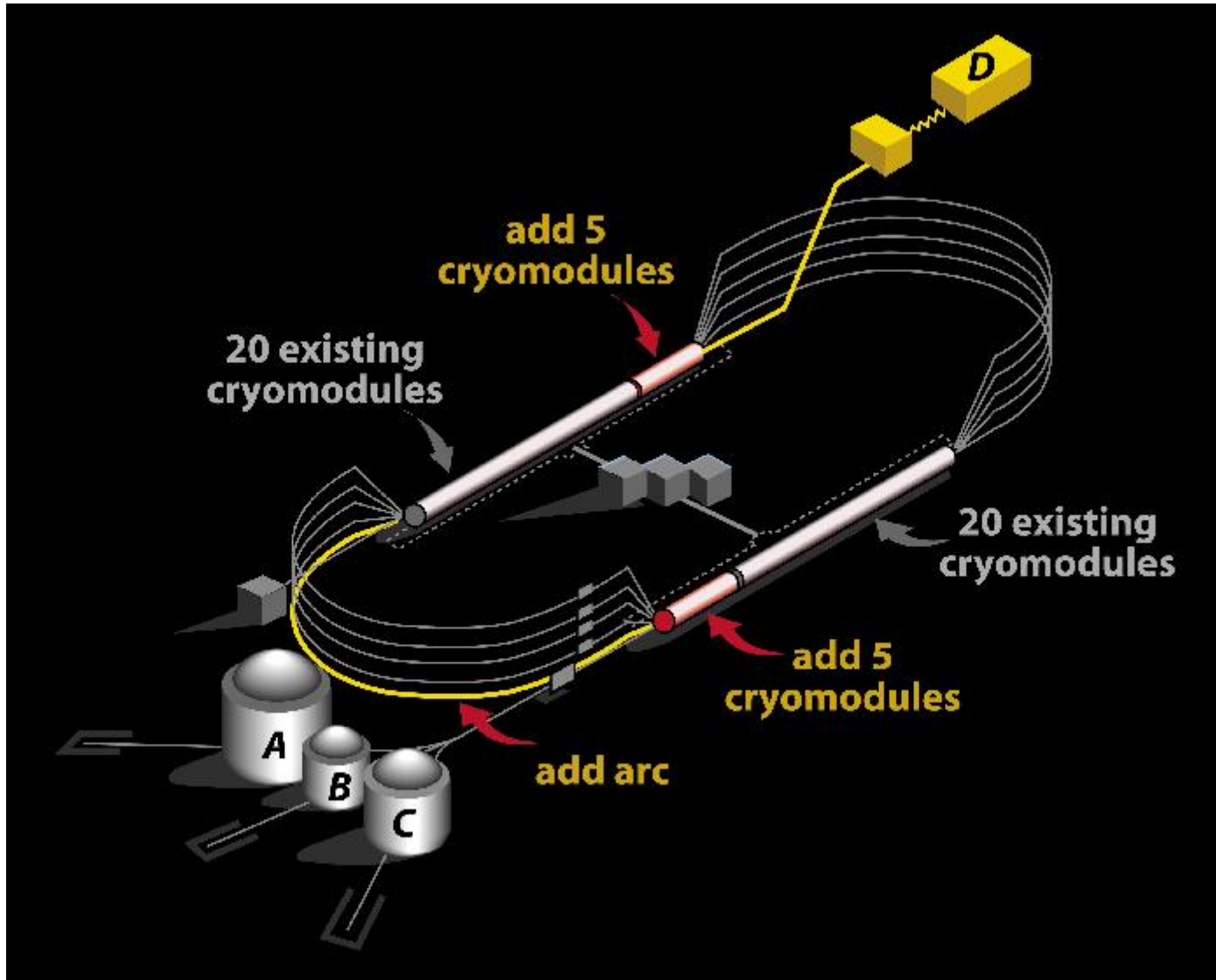

Proposed detector facilities: JLab@12 GeV

D

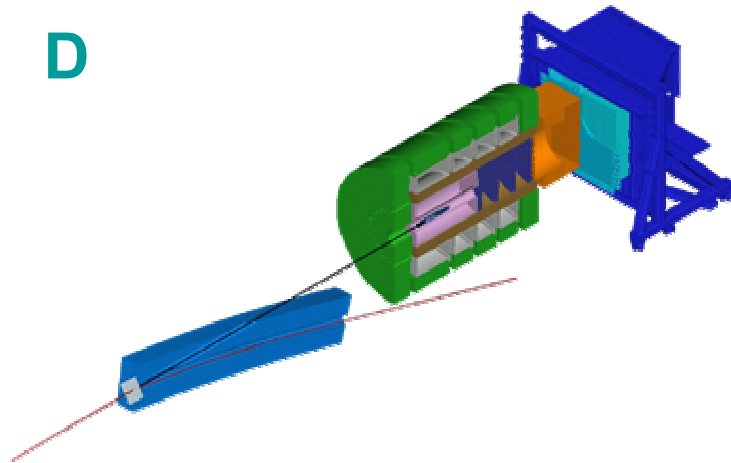

9 GeV tagged polarized photons and a 4π hermetic detector

B

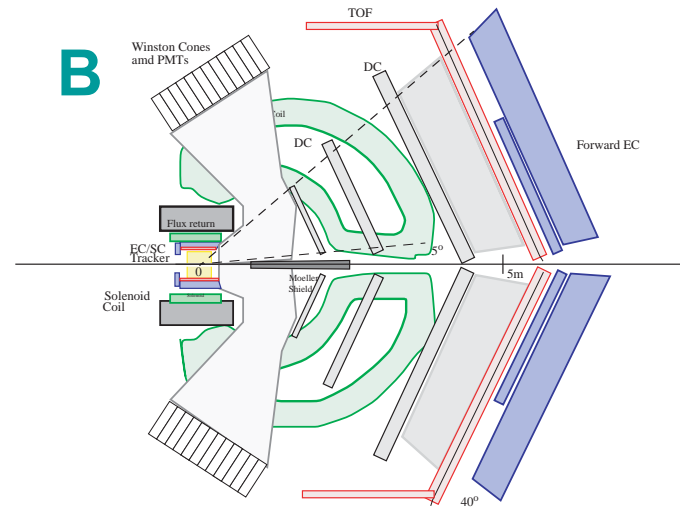

CLAS upgraded to higher luminosity and coverage

C

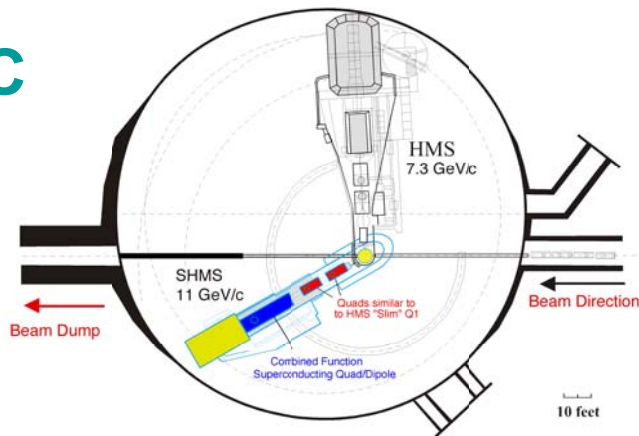

Super High Momentum Spectrometer (SHMS) at high luminosity and forward angles

A

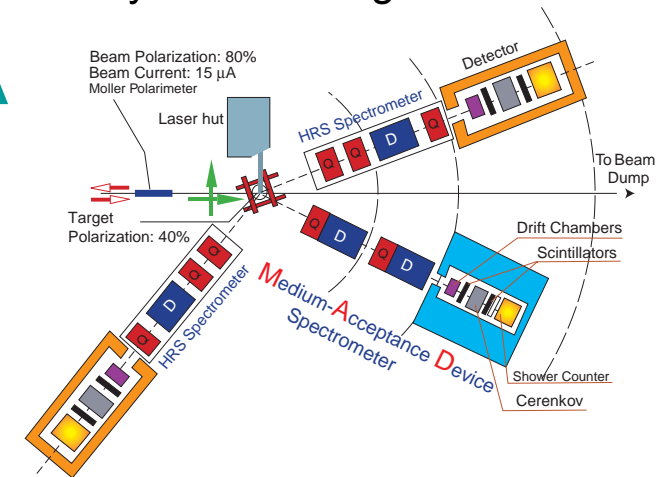

Medium Acceptance Detector (MAD) at high luminosity and intermediate angles and Big Bite spectrometer

Contributions to Future facilities: JLab@12 GeV



Design of Magnet for Hall D photon tagging spectrometer (Glasgow)

Polarised photon R&D (Glasgow)

Polarised nucleon target development (Edinburgh/Glasgow)

Nucleon Polarimetry (Edinburgh)

Focal plane detector for large acceptance "Big Bite" Spectrometer (Glasgow)

Hall D Magnet design

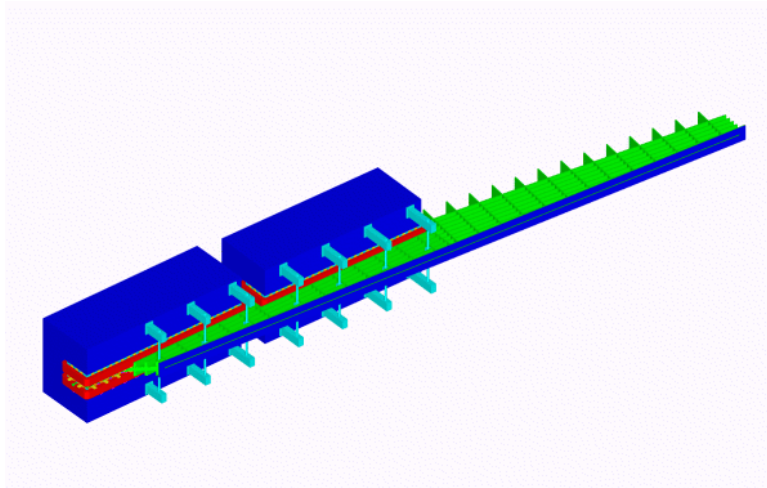

Big Bite

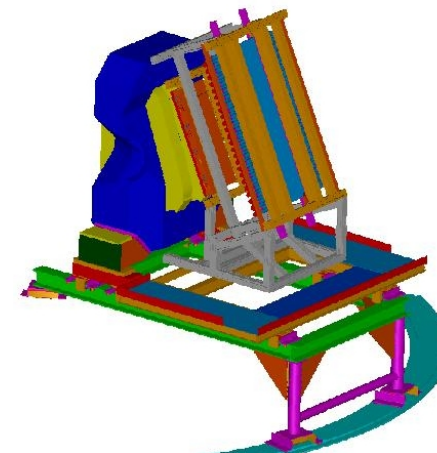

DVCS at Hermes : Recoil Detector

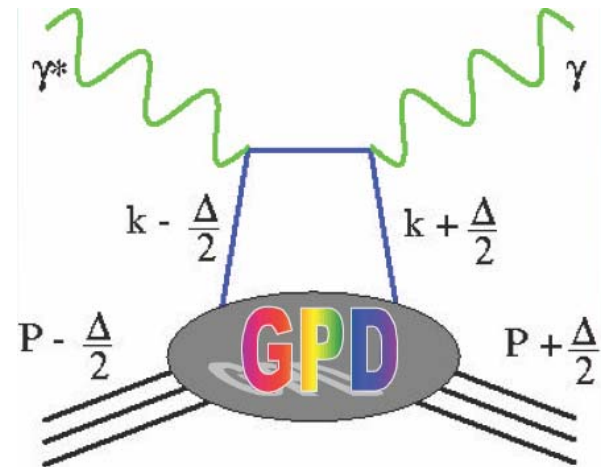
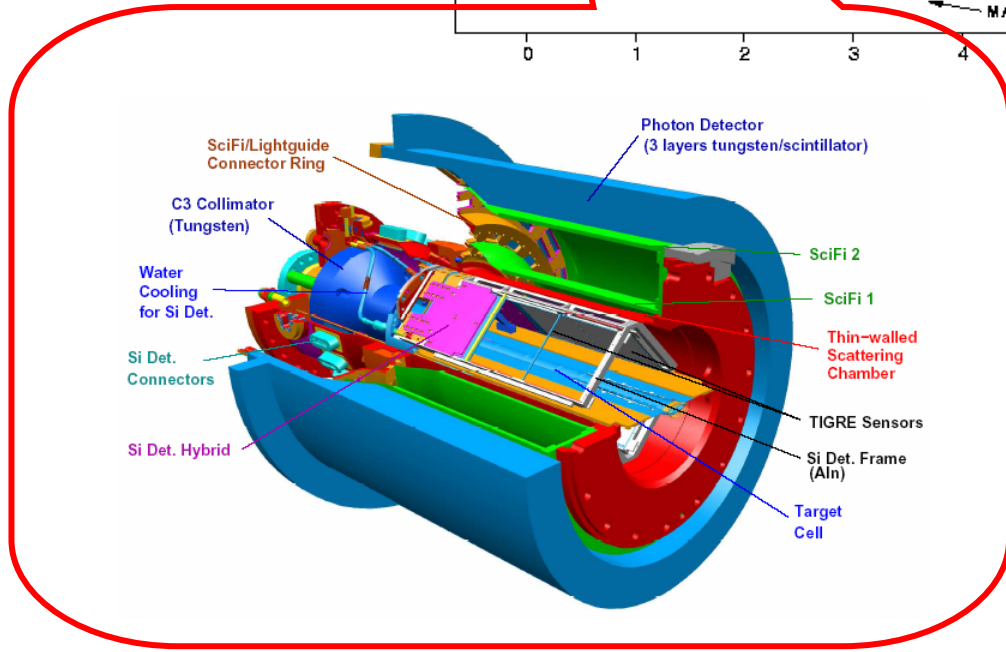
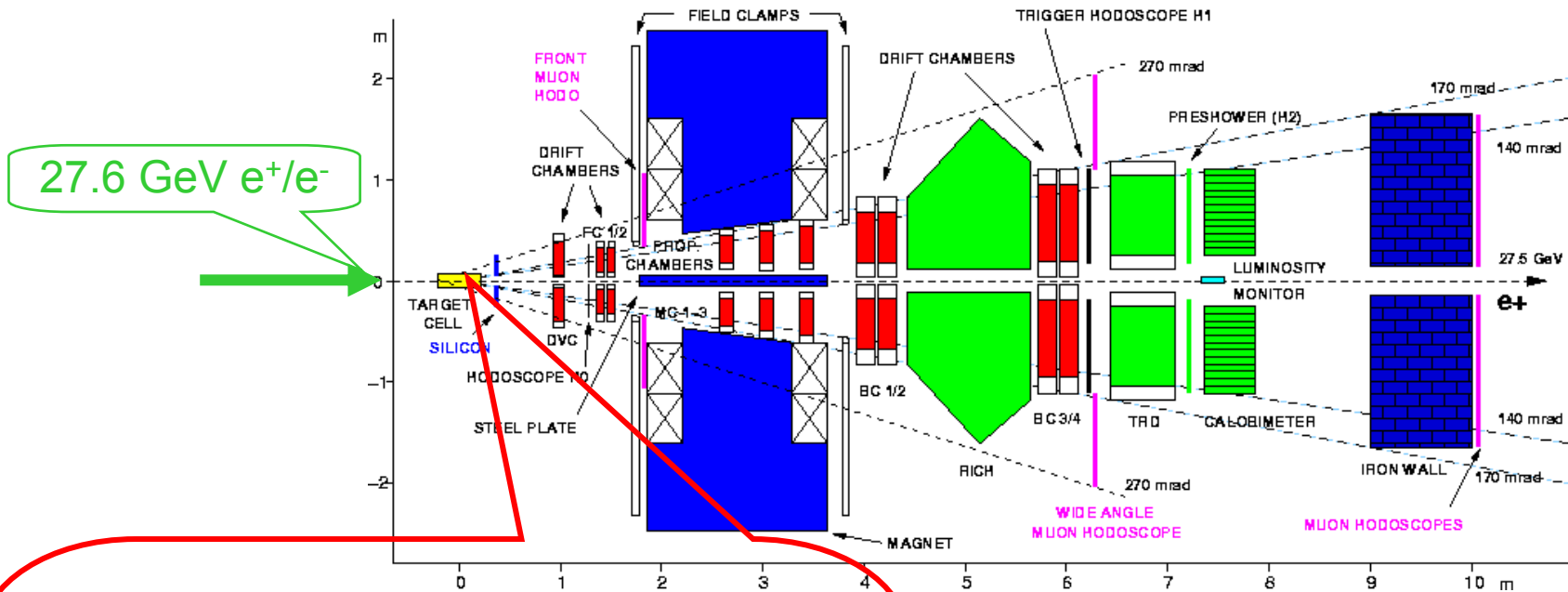

PANDA@FAIR

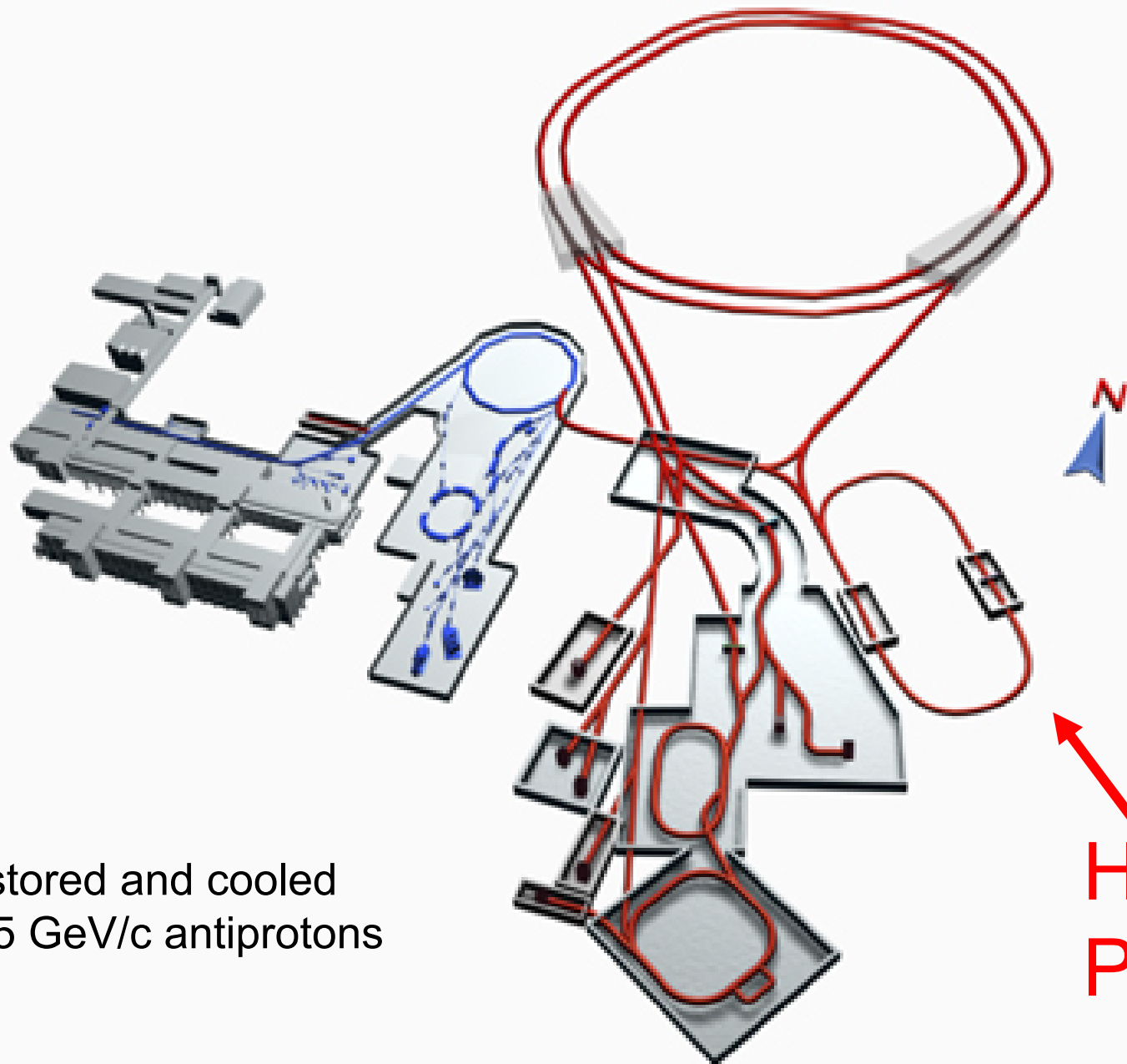

10^{11} stored and cooled
1 - 15 GeV/c antiprotons

HESR /
PANDA

Physics : PANDA@FAIR

2-body Thresholds

Molecules

Gluonic Excitations

qq_bar states

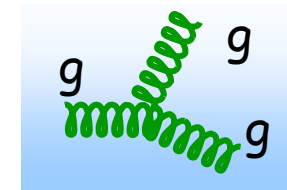
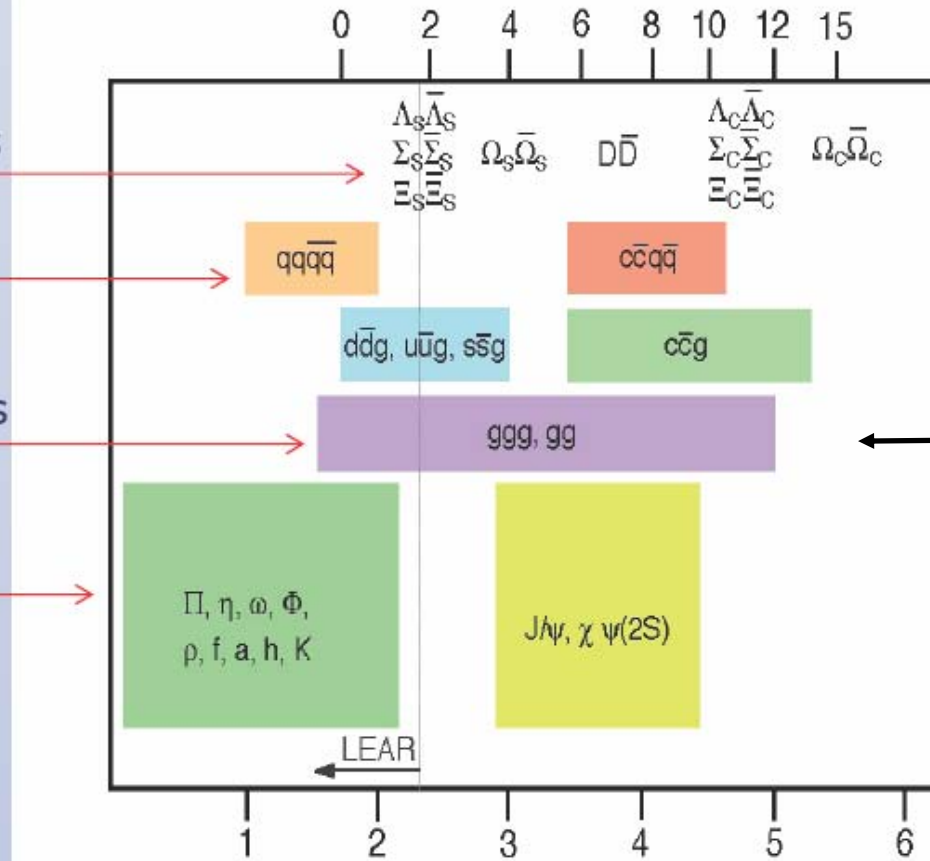

Physics : PANDA@FAIR

Glueballs – exotic objects with **no** quarks. Comprised entirely of gluons!

Fundamental test of QCD

Antiproton annihilations well suited to creating gluon rich final states

Antiproton annihilations are gluon-rich

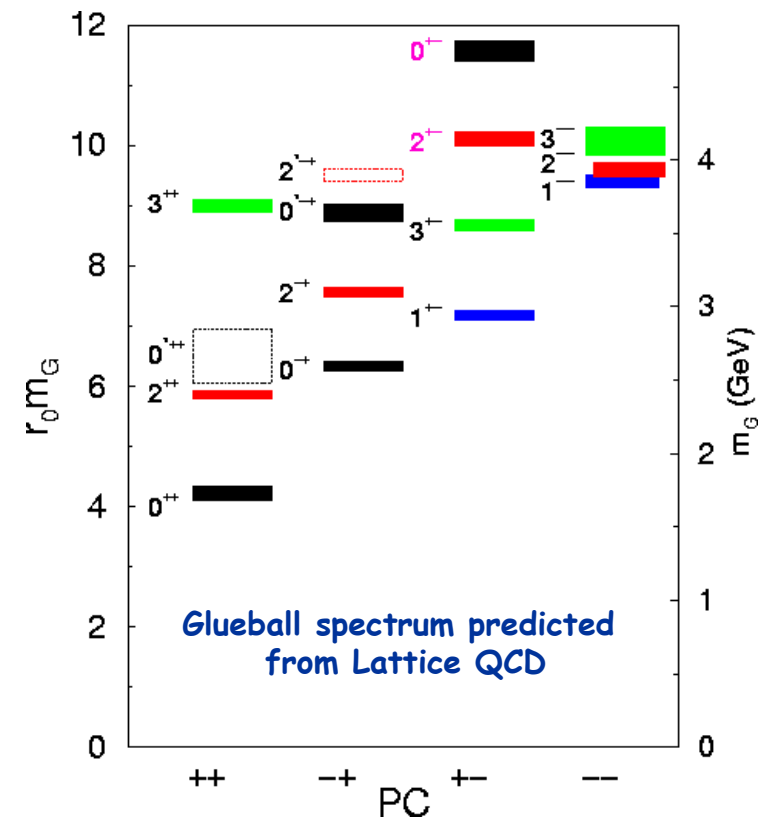
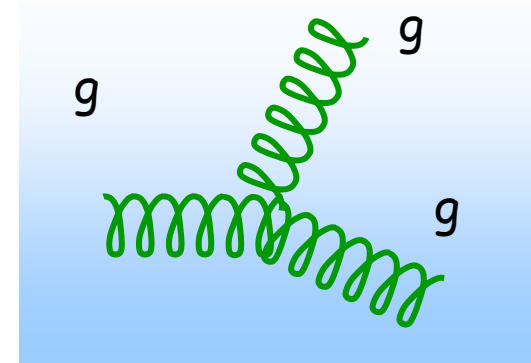
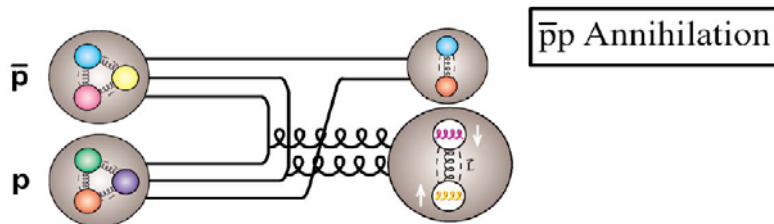

Contributions to Future facilities : PANDA@FAIR



- Design of magnetic solenoid (Glasgow)
- RICH (Glasgow)
- Endcap DIRC (Edinburgh)
- Nucleon Polarimetry (Edinburgh)
- Grid computing technology (Glasgow)
- Simulations (Glasgow/Edinburgh)

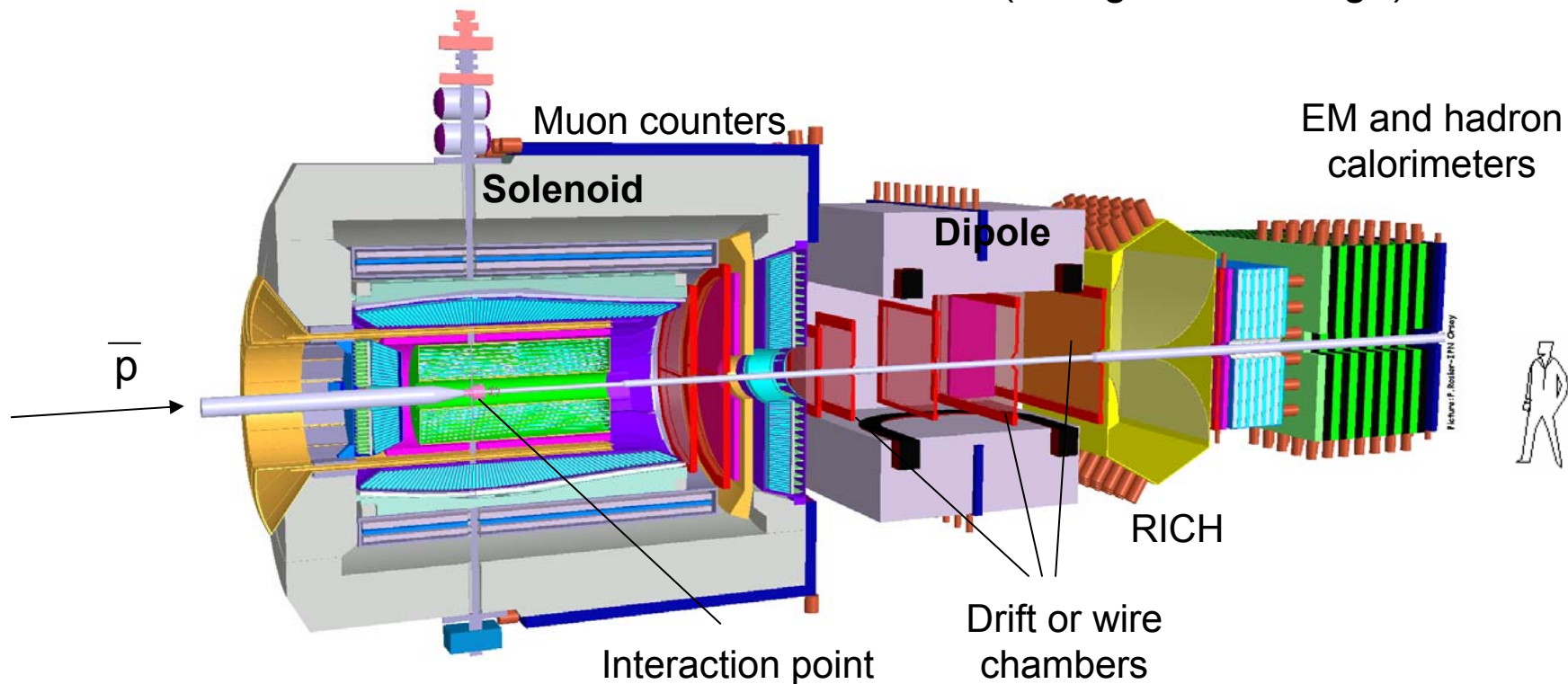

Summary

- Edinburgh and Glasgow groups will utilise four major new facilities which come online in the next 1-6 years (MAXLab@0.25GeV, MAMI@1.5GeV, JLab@12GeV PANDA@FAIR)
- We are in a good position to exploit and develop these new opportunities