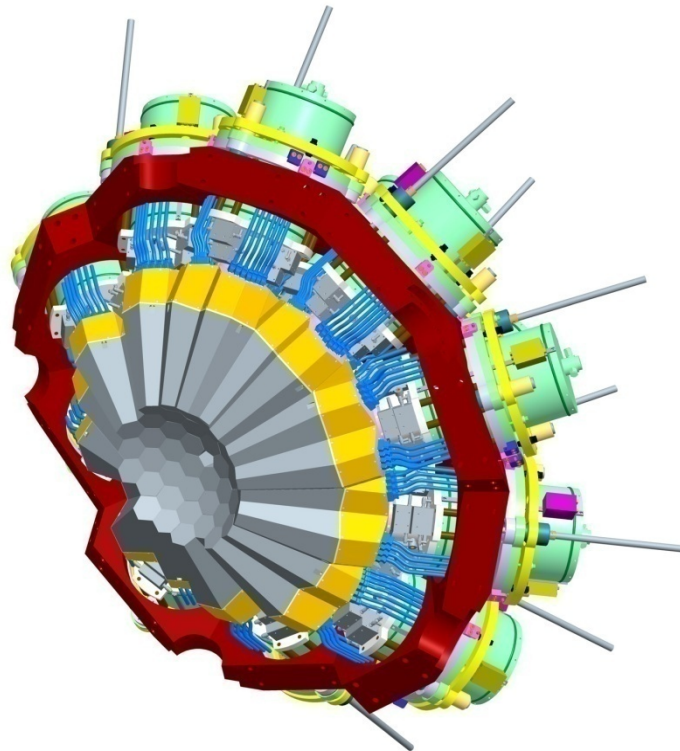


# The AGATA Spectrometer



The University of Liverpool

The University of Manchester

The University of Surrey

The University of the West of Scotland

The University of York

STFC Daresbury Laboratory



# Contents

1. Executive summary
2. The status of the project
3. Information for the Oversight Committee
4. Project programme by Work Package
  - a. WP1 Detector-specification measurement and cryostat assembly and commissioning
    - i. Summary of WP tasks
    - ii. Activities during the past 6 months
    - iii. Activities during the next 6 months
    - iv. Financial statement
    - v. Resource usage
    - vi. Milestones
    - vii. Gantt chart
    - viii. Earned value analysis
  - b. WP2 Interaction position determination using pulse-shape analysis
    - i. Summary of WP tasks
    - ii. Activities during the past 6 months
    - iii. Activities during the next 6 months
    - iv. Financial statement
    - v. Resource usage
    - vi. Milestones
    - vii. Gantt chart
    - viii. Earned value analysis
  - c. WP3 Experiment simulations and verification of tracking
    - i. Summary of WP tasks
    - ii. Activities during the past 6 months
    - iii. Activities during the next 6 months
    - iv. Financial statement
    - v. Resource usage
    - vi. Milestones
    - vii. Gantt chart
    - viii. Earned value analysis
  - d. WP4 Support for setup and running of initial experiments
    - i. Summary of WP tasks
    - ii. Activities during the past 6 months
    - iii. Activities during the next 6 months
    - iv. Financial statement
    - v. Resource usage
    - vi. Milestones
    - vii. Gantt chart
    - viii. Earned value analysis

- e. WP5 Electronics and Graphical User Interface (GUI) software
  - i. Summary of WP tasks
  - ii. Activities during the past 6 months
  - iii. Activities during the next 6 months
  - iv. Financial statement
  - v. Resource usage
  - vi. Milestones
  - vii. Gantt chart
  - viii. Earned value analysis
  
- f. WP6 Mechanical design
  - i. Summary of WP tasks
  - ii. Activities during the past 6 months
  - iii. Activities during the next 6 months
  - iv. Financial statement
  - v. Resource usage
  - vi. Milestones
  - vii. Gantt chart
  - viii. Earned value analysis
  
- g. WP7 Project management
  - i. Summary of WP tasks
  - ii. Activities during the past 6 months
  - iii. Activities during the next 6 months
  - iv. Financial statement
  - v. Resource usage
  - vi. Milestones
  - vii. Gantt chart
  
- h. WP8 Equipment procurement and running costs
  - i. Summary of WP tasks
  - ii. Activities during the past 6 months
  - iii. Activities during the next 6 months
  - iv. Financial statement
  - v. Milestones
  - vi. Gantt chart
  
- 5. Financial statement, whole project
  
- 6. Overall project plan
  
- 7. Risk register
  
- 8. UK AGATA Publications

## 1 Executive summary

During the last six months the AGATA project has made major advances. The project has moved forward from the first installation of many of its components in Legnaro to starting the first physics campaign with initially 3(4) triple cluster detectors. This is a fantastic achievement involving all members of this huge international collaboration. The UK has played a key part in this success leading the project in many areas.

The work of the UK in this grant is split into 7 work packages plus the main capital work package. In work package 1 the notable highlights are that Liverpool is now an official test site for AGATA detectors and the staff have been trained in detector handling and exchange. Liverpool now perform customer acceptance test on capsules for the collaboration. In work package 2 the UK has successfully performed a comprehensive scan of the first AGATA asymmetric capsule and supplied the pulse shape data-set to the AGATA collaboration. This work is vital for the optimum performance of the spectrometer. Work package 3 has made significant progress and all the simulation codes are now available in the UK for the simulation of AGATA performance and complex experimental set-ups. The group has performed simulations for the UK led collaborations submitting proposals to the Legnaro PAC in February 2010 and is busy setting up the simulations for the GSI phase. The UK is now in an excellent position for future physics exploitation of the instrument. Work package 4 has seen a lot of activity over the period with the setting up and running of source and in-beam commissioning experiments in Legnaro. There have now been 7 in-beam tests in 2009. These tests each had specific aims, most of which were satisfied. This work is summarised in the work package 4 report. Work package 5 has concentrated on the successful production and commissioning of the full EDAQ chain for 3 triple clusters and is currently working on the fourth system for operation in February 2010. The UK responsibility is for the digitizers and co-ordination of the pre-processing electronics. In work package 6 work has concentrated on optimising the set-up of the mechanical structure with detectors in Legnaro and has made significant progress in the conceptual mechanical design for the next phase of operation at GSI. The design of the array at GSI is very different from that at Legnaro due to the very high recoil velocity. WPs 7 and 8 proceeded as scheduled.

The UK plays leading roles internationally and indeed is key member of the collaboration. The UK is responsible for all the mechanical design, procurement and installation of AGATA and owns all the designs. The UK designed, built and controls the front end electronics, the digitizers. The UK is the only site in Europe to scan and characterise the AGATA detectors. Without these scans the extraction of vital position information from the pulse shape analysis is not possible and tracking not possible.

The UK has international leadership and manages the project. Prof Paul Nolan is the chair of the AGATA Steering Committee and Prof John Simpson is the International Project Manager and chairs the AGATA Management Board. Andy Boston, Ian Lazarus and John Strachan chair working groups within the project. In addition to these leadership roles UK scientists have been appointed to coordinate both of the first two physics campaigns. Prof Sean Freeman is physics coordinator for Legnaro, Prof Mike Bentley is physics coordinator for the GSI experiments.

The AGATA project is the biggest spectrometer project in Europe for Nuclear spectroscopy and will be used at European Large Scale facilities, Legnaro, GANIL and GSI and will be a fundamental part of the experimental programmes at SPIRAL2 and FAIR. At FAIR AGATA is the high resolution spectrometer for the HISPEC project in NuSTAR. AGATA's science output means that it will be one of the frontier instruments in the next NuPECC Long Range Plan for 2010 onwards. AGATA will support ~70% of the UK nuclear physics researchers over its lifetime.

These facts make the decision of STFC to not support the project and make a “strategic withdraw” from the project incredible and unbelievable. AGATA is the top UK nuclear physics project, which is on the brink of its science programme after seven years of investment by the UK. The withdrawal of STFC from the project will have a devastating effect on the project due to the UK’s involvement in vital key areas. The UK expertise cannot be replaced in the medium term and the whole of European Nuclear Spectroscopy will feel the effects.

Withdrawal will have a huge negative impact on the whole UK science programme with international partners. Withdraw will affect the scheduling and planning of nuclear spectroscopy projects at large scale accelerator facilities in Europe (GSI, GANIL and Legnaro). In Europe nuclear physics is funded to a much higher level than in the UK and STFC should not be surprised by the international outcry and disbelief at its decision making process.

## **2 The status of the project**

The project is now about to embark on its first physics campaign in Legnaro. Three triple detectors are already installed and working, others will follow soon. At its meeting in June 2009 the AGATA Steering Committee (ASC) decided that AGATA will remain in Legnaro until end June 2011. The Legnaro PAC has awarded beam time to AGATA for a series of commissioning experiments during 2009. The PAC has also awarded beam time for the first three physics experiments which will take place early in 2010. The next meeting of the PAC in February will consider many more requests for experiments. The ASC also agreed (in December 2009) that the next two sites will be GSI (earliest start October 2011) and then GANIL (earliest start April 2013).

### 3 Actions and information for the Oversight Committee

This section reports on the actions taken following the last meeting of the Oversight Committee.

---

*(i) In their next report, the Collaboration should provide a statement of Earned Value Analysis and should provide the total cost of risks as this information would be useful both to the Committee and to themselves.*

**Action:** Collaboration

**Done:** See the individual work package reports.  
The abbreviations used in the analysis are as follows.

- **EAC** - Estimate at Completion
- **BAC** - Budget at Completion
- **VAC** – Variance at Completion
- **BCWS** – Budget Cost of Work Scheduled. (the planned cost of work done by a certain date)
- **ACWP** – Actual Cost of Work Performed. (the actual cost of actual work done by a certain date)
- **BCWP** – Budgeted Cost of Work Performed. (the planned cost of actual work done)
- **SV** – Schedule Variance. (Is work ahead/behind schedule)
- **CV** – Cost Variance. (Difference between actual cost and budgeted cost of work performed. E.g. over/under budget)
- **CPI** – Cost performance Index.
- **SPI** – Schedule Performance Index

---

*(ii) The Collaboration was encouraged to enter into dialogue with their partners regarding scope and descope options. For the next meeting, the Collaboration was requested to prepare a list of descope options and include these in their risk register. The risks should be weighted and descope options prioritised in order to have a plan if some of the risks came about. The Committee stressed that if the Collaboration spent extra at this early stage, they might have insufficient resources for later in the project. They should plan to descope if extra spending was anticipated.*

**Action:** Collaboration

**Done:** This list of items in priority order was submitted to the office in September. The table gives the remaining items of equipment to be spent for AGATA in priority order

Item	Work package	Cost (£)	Implication of not purchasing this item
Cryostat	8	68	Project unable to mount detectors.
Digitisers first batch	8	81	Project unable to instrument detectors.
Mechanical frame 1	6	50	Funds would have to be found from collaboration. No funding identified. Delays in the project for the GSI phase.
Digitiser upgrade	8	70	Insufficient components for electronics.
Digitisers second batch	8	102	Insufficient electronics for detectors.
Detector infrastructure	8	23	UK not fulfilling its MoU obligations. Detectors will not work.
Mechanical frame 2	6	45	Funds would have to be found from collaboration. No funding identified. Delays in the project for the GANIL phase.
Test cryostat	1	32	Delays in detector scanning.
<b>Total</b>		<b>471</b>	

---

*(iii) The Committee had some concerns about the financial reporting. They felt that the international collaboration as a whole should think about costs and that there should be international control of this. Also, they should think about effort on the project and keep within a fixed budget. The Collaboration was urged to improve their financial management resources, and Professor Nolan and Professor Simpson were asked to ensure that the correct financial information was presented to the Committee. The Collaboration agreed to amend the accounts and to resubmit them to the Office as soon as possible.*

**Action:** Collaboration  
**Done:** The revised accounts were submitted to the office and approved.  
The latest statements follow on from these.

---

*(iv) The Collaboration was also urged to have someone in place with dedicated project management skills.*

**Done:** Project Manager in place.

---

*(v) The Committee wanted the Collaboration to provide as soon as possible a table giving an overview of the global picture showing the contribution of each of the partners.*

**Action:** Collaboration  
**Done:** This was submitted to the office in September. The submission, with some minor updates is reproduced below.



### Contributions of other AGATA partners

The figures given below are in three sections. The first (2003-2008) includes numbers from the AGATA Steering Committee (ASC) which are included in the new MoU. The second (host laboratories) are the numbers agreed by the ASC as the costs likely to be incurred by the host laboratories for the local infrastructure when AGATA is used at that laboratory, these items do not move with AGATA. The third (post 2008) are estimates as these figures have not been agreed by the ASC. All funds are quoted in euros without tax included.

#### **Period 2003-2008**

Capital investment and human resources committed for the AGATA R&D phase and the five-unit AGATA system.

Country	Funds committed in k€ (2003-2008)	Personnel in person months (2003-2007)
Bulgaria	0	45
Finland	2	8
France	1400	1145
Germany	1228	336
Italy	1400	737
Poland	0	60
Romania	57	40
Sweden	850	175
Turkey	750	70
UK	950	455
<b>Total</b>	<b>6637</b>	<b>3031</b>

#### **Host laboratories**

The Hosts will incur costs directly related to the installation and operation of the AGATA system. Estimates of these costs and the required human resources are given below.

Capital investment without general infrastructure costs and human resources planned to be provided by the Hosts for the installation, commissioning and operation of AGATA assuming an 18-month operation period at each site.

Country	Host	Planned capital investment [k€]	Personnel in person months
Italy	LNL	230*	150
France	GANIL	190	101
Germany	GSI	200	171
* Already spent.			

## Investment post 2008

Country	MoU 2008 AGATA Planned new capital investment [k€]	Funds approved [k€]	Funds committed [k€]	Comment
Bulgaria	25			
Finland	25			
France	2460	2460	0	2010 - 2014
Germany	2460	950	950	Bid in 2011 for funding to get to the MoU level, a total of 2460
Italy	2460	1127	952	Bidding for remaining funds up to the 2460 value as agreed in the MoU. Italy will maintain the same level of commitment to AGATA for the foreseeable future.
Poland	25			
Romania	180			
Sweden	1640			Bid in March 2010
Turkey	820			Will bid in near future
UK	2460	970	*	

\*Commitment will be reported to the OC.

(vi) For the next and subsequent meetings the Committee also wanted the Collaboration to provide a table showing development of detectors and electronics as a function of time and origin.

**Action:** Collaboration  
**Done:** See below.

The AGATA International collaboration is currently defining a roadmap for the project to define its staged development from the AGATA 1/3 as defined in the MoU to the full  $4\pi$  spectrometer. The first stage of this is to define in detail all aspects of the project including the definition of the spectrometer for the first two physics campaigns at Legnaro and GSI. This is being prepared by the AGATA AMB.

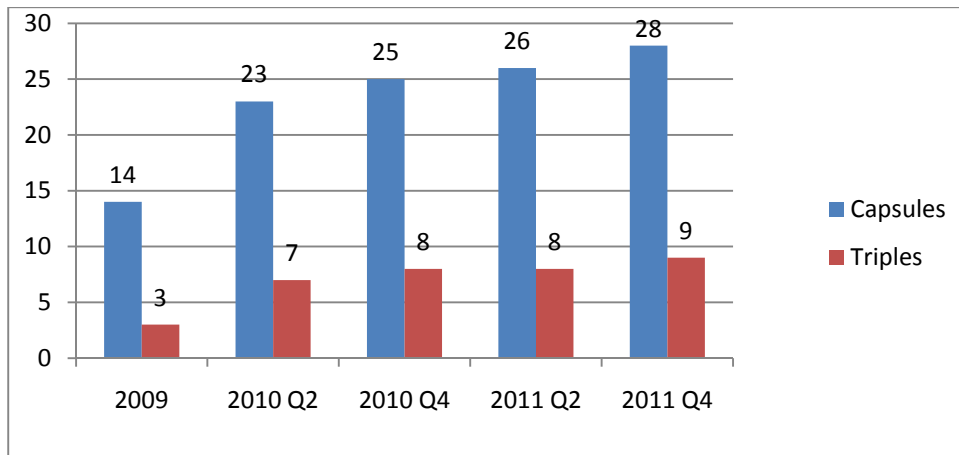
The AGATA collaboration has made the decision that in the short term for at least up to 8 triple clusters the AGATA spectrometer is to remain as it is now. The collaboration has decided to set-up a series of working groups in 2010 to discuss the next phases of the project. Developments have to take into account cost, technical developments and available effort within the collaboration. The specific plans for detector and electronics are given below.

### **Detector status**

15 capsules ordered for the demonstrator phase. (3 UK)

13 capsules already ordered for the 1/3 phase (this project).

The timescales, in the chart below, show that for the Legnaro phase of the project (to Q2 2011) AGATA can operate 7-8 triples. For the GSI phase (from Q4 2011) AGATA will have  $\geq 10$  triples. Note that funding already exists in Italy and France for further orders (10 capsules) in 2010, the delivery of these is not included in the graph below.



### **Electronics status**

The UK is responsible for the first stage of the electronics, the digitizers. The timescales for the production of digitizers is given in the report of WP5. The UK is tendering for the production of a further 7 digitizers, 4 funded from the UK and 3 in a contract placed by STFC with INFN. This will give a total of 25 digitizers on a timescale to match the detector deliveries. As discussed in WP5 the collaboration needs to decide in 2010 its strategy for further production of the current digitizer design and parallel production for upgraded electronics. The responsibility for the pre-processing electronics and DAQ lies within other countries in the collaboration who are working to the same timescales.

*(vii) For the next meeting the Collaboration should colour code their risks and should also show percentage completion of tasks on their Gantt charts.*

**Action:** Collaboration  
**Done:** Risk Register colour coded. Gantt charts show percentage completion as a black line in the bars.

*(viii) The Collaboration was asked to provide a more concise presentation for the next meeting focusing on updates since the report was submitted as well as their responses to the Committee's recommendations.*

**Action:** Collaboration  
**Done:** This report is shorter.

*(ix) Professor Simpson agreed to submit his best estimates for upcoming years for funding at Daresbury to the office to enable re-profiling of the allocations for electronics (digitisers) and mechanics.*

**Action:** Collaboration and Office  
**Done.**

## 4 Project Programme by Work Package

### 4(a) Work Package 1 **Detector specification measurement and cryostat assembly and commissioning**

**Leader:** Dr A. J. Boston (Liverpool)

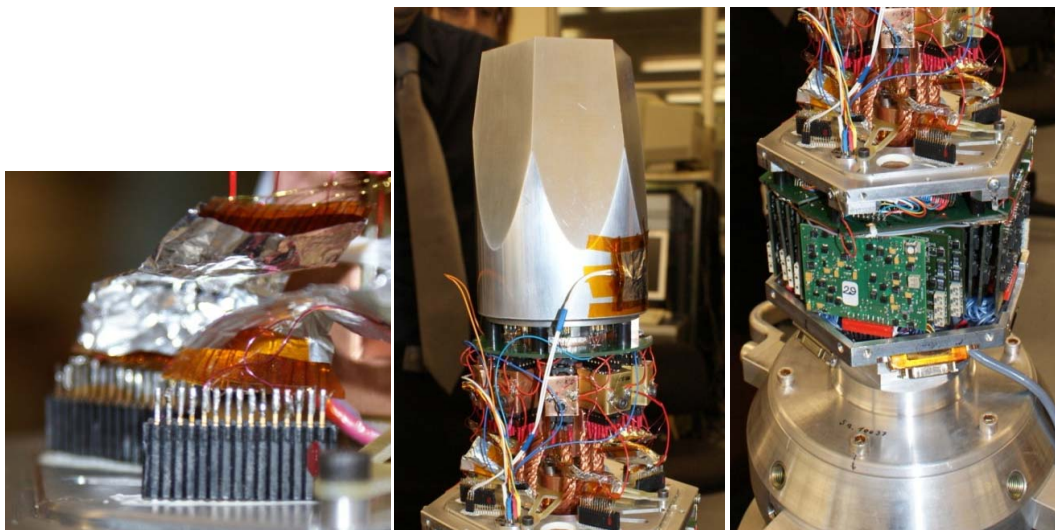
**Institutes:** Liverpool

#### (i) **Brief summary of WP tasks**

- Detector specification measurement
- Detector assembly for scanning
- Triple-cryostat assembly

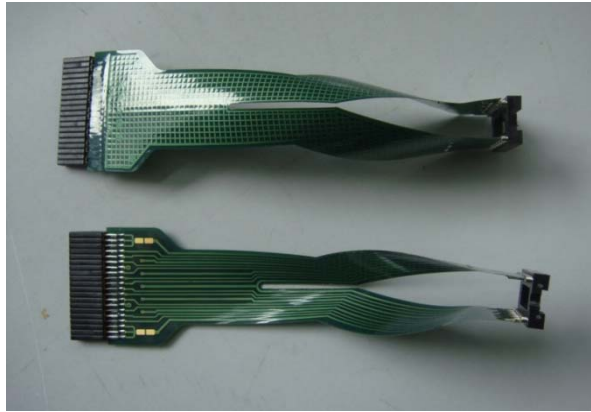
#### (ii) **Activities during the past 6 months**

The C001 asymmetric detector required for coincidence measurement as part of the detector characterisation work in WP2 has been repaired and commissioned for scanning in Liverpool. Figure 1 illustrates the internal cabling of the test cryostat. Figure 4(a)1 (left) shows the cold-warm feed through which was found to be the main sources of issues during the reassembly due to wiring breakages during cooling. Figure 4(a)1 (middle) shows the completed detector assembly with the end cap removed. Figure 4(a)1 (right) shows the warm preamplifiers fully mounted.



**Figure 4(a)1: Detector assembly for C001**

The reassembly delays due to the fragile nature of the wiring may be lessened by the use of new Kapton cabling developed at the University of Cologne. If the thermal leakage issues highlighted by the new design, shown in Figure 4(a)2, can be eliminated then they will be tested during the next quarter.



**Figure 4(a)2: New Kapton internal cabling**

A new pumping system has been delivered and installed in Liverpool; subsequently the detector acceptance system has been commissioned and accredited. The Daresbury test cryostat and the first detector capsules for acceptance testing have been shipped to Liverpool. Additional digital electronics from other projects in Liverpool will be used to allow the acceptance system and characterisation system to fully run in parallel. The plan was to use Gretina digitiser modules; however there have been delays in procuring these from the USA. A potential suitable alternative has been identified.

Detector capsules A004 and A006 are on site in Liverpool along with an additional test cryostat. A004 has been assembled for acceptance testing in the Daresbury cryostat. A006 has been assembled ready for commissioning for scanning.

The Liverpool technician who will work on the detector assembly and acceptance testing has started. He has been trained in the essential processes in Cologne.

The essential spare component parts for the test cryostats have been identified (these will speed up trouble shooting of capsules) and will be ordered alongside the triple cluster cryostat, as they are from the same vendor (CTT).

The firmware on the existing 40 channels of Gretina digitisers which are presently used jointly for detector acceptance and characterisation has been upgraded. The new firmware allows for channel by channel optimisation of the preamplifier delay time constant, which significantly improves the performance of the core channel relative to the segments. We have been working with colleagues to overcome some small issues with the latest release which impact performance at higher count rates >10 kHz.

### **(iii) Activities during the next 6 months**

Detector A006 will be commissioned in the existing cryostat for characterisation in WP2. The acceptance testing of new capsules (beginning with A004) delivered directly from the manufacturer will commence in the Daresbury test cryostat. Spare parts for cryostats will be ordered.

(iv) Financial Statement: Work Package 1

Workpackage 1 Finance Summary (all figures in £k)

	Approved (excluding contingency)  (1)	Transfers  (1a)	Actual spend in previous years (2)		Current year 2009/10		Latest estimate of future requirement (5)			Total		Variance	
			2008/09	for each FY	Actual Spend to end Sept 09  (3)	Projected spend this year (4)	2010/11	2011/12	2012/13	Actual spend (2+3)  (6)	Projected spend (2+4+5) (7)	Actual (6-1-1a)	Projected (7-1-1a)
<b>University Staff Effort Costs*</b>													
Liverpool University Effort (inc student stipend)	119.45	10.00	6.08		12.83	25.66	39.71	38.36	19.64	18.91	129.45	-110.55	0.00
Manchester University Effort													
Surrey University Effort (inc student stipend)													
UWS Effort													
York University Effort (inc student stipend)													
<b>University Sub-Total</b>	<b>119.45</b>	<b>10.00</b>	<b>6.08</b>	<b>0.00</b>	<b>12.83</b>	<b>25.66</b>	<b>39.71</b>	<b>38.36</b>	<b>19.64</b>	<b>18.91</b>	<b>129.45</b>	<b>-110.55</b>	<b>0.00</b>
<b>STFC Lab Costs</b>													
Daresbury													
<b>STFC Lab Sub-Total</b>													
Student Fees Liverpool	1.33		0.50		0.27	0.55	0.28	0.00	0.00	0.77	1.32	-0.56	0.00
Equipment Liverpool	41.70		0.00		5.78	41.70				5.78	41.70	-35.93	0.00
Travel Liverpool	15.99		1.71		2.81	4.29	4.28	3.89	1.83	4.51	15.99	-11.48	0.00
Other Directly Allocated costs (eg consumables) Liverpool	30.65				6.30	5.39	15.49	9.77		6.30	30.66	-24.35	0.00
Liverpool University Estates costs	38.72	2.49	1.21		3.77	7.55	12.85	12.96	6.64	4.99	41.21	-36.23	0.00
Manchester University Estates costs													
Surrey University Estates costs													
UWS Estates costs													
York University Estates costs													
<b>University Estates costs total</b>	<b>38.72</b>	<b>2.49</b>	<b>1.21</b>		<b>3.77</b>	<b>7.55</b>	<b>12.85</b>	<b>12.96</b>	<b>6.64</b>	<b>4.99</b>	<b>41.21</b>	<b>-36.23</b>	<b>0.00</b>
Liverpool University Indirect costs	130.63	8.40	4.08		12.74	25.48	43.36	43.72	22.39	16.82	139.03	-122.21	0.00
Manchester University Indirect costs													
Surrey University Indirect costs													
UWS Indirect costs													
York University Indirect costs													
<b>University Indirect costs</b>	<b>130.63</b>	<b>8.40</b>	<b>4.08</b>		<b>12.74</b>	<b>25.48</b>	<b>43.36</b>	<b>43.72</b>	<b>22.39</b>	<b>16.82</b>	<b>139.03</b>	<b>-122.21</b>	<b>0.00</b>
<b>Total (Excluding VAT and WA)</b>	<b>378.48</b>	<b>20.89</b>	<b>13.57</b>		<b>44.50</b>	<b>110.62</b>	<b>115.98</b>	<b>108.69</b>	<b>50.50</b>	<b>58.08</b>	<b>399.36</b>	<b>-341.29</b>	<b>0.00</b>
Working allowance													
VAT	7.30		0.00		0.87	7.30	0.00	0.00	0.00	0.87	7.30	-6.43	0.00
17.50%													
15.00%													
<b>Total (including VAT &amp; WA)</b>	<b>385.77</b>	<b>20.89</b>	<b>13.57</b>		<b>45.37</b>	<b>117.92</b>	<b>115.98</b>	<b>108.69</b>	<b>50.50</b>	<b>58.94</b>	<b>406.66</b>	<b>-347.72</b>	<b>0.00</b>
<b>Rolling Grant Effort</b>													
Liverpool Rolling Grant Effort	34.65		5.96		5.02	10.03	8.87	6.73	3.06	10.98	34.65	-23.67	0.00
Liverpool Rolling Grant Estates	11.90		2.12		1.65	3.30	3.17	2.28	1.04	3.77	11.90	-8.13	0.00
Liverpool Rolling Grant Indirect	40.13		7.14		5.75	11.50	10.31	7.68	3.50	12.89	40.13	-27.24	0.00
<b>Total Rolling Grant Cost</b>	<b>86.68</b>		<b>15.22</b>		<b>12.42</b>	<b>24.83</b>	<b>22.35</b>	<b>16.69</b>	<b>7.60</b>	<b>27.64</b>	<b>86.68</b>	<b>-59.04</b>	<b>0.00</b>
<b>Total (including VAT &amp; WA &amp; Rolling Grant)</b>	<b>472.45</b>	<b>20.89</b>	<b>28.79</b>		<b>57.79</b>	<b>142.75</b>	<b>138.32</b>	<b>125.38</b>	<b>58.10</b>	<b>86.58</b>	<b>493.34</b>	<b>-406.76</b>	<b>0.00</b>

(v) Resource Usage: Work Package 1

WP1								
NAME	INSTITUTE	% FTE 2008/09	% FTE 2009/10	% FTE 2010/11	% FTE 2011/12	% FTE 2012/13	Total Effort	Effort Remaining
A Boston	Liverpool	0.050	0.125	0.125	0.100	0.050	0.450	0.275
H Boston	Liverpool	0.050	0.150	0.200	0.200	0.100	0.700	0.500
Technician grade E	Liverpool	0.000	0.500	1.000	1.000	0.500	3.000	2.500
Liverpool Student	Liverpool	0.100	0.200	0.100	0.000	0.000	0.400	0.100
<b>Rolling Grant</b>								
M Norman	Liverpool	0.175	0.375	0.325	0.225	0.100	1.200	0.650

(vi) Milestones: Work Package 1

<u>Milestone No.</u>	<u>Work Package</u>	<u>Milestone</u>	<u>Target Date</u>	<u>Status</u>
M1.2	WP1	Successful detector measurements	05 Oct 09	Complete
		Liverpool to be accredited detector acceptance centre	05 Oct 09	Complete
M1.3	WP1	1 <sup>st</sup> Detector successfully mounted	05 Jan 10	Complete

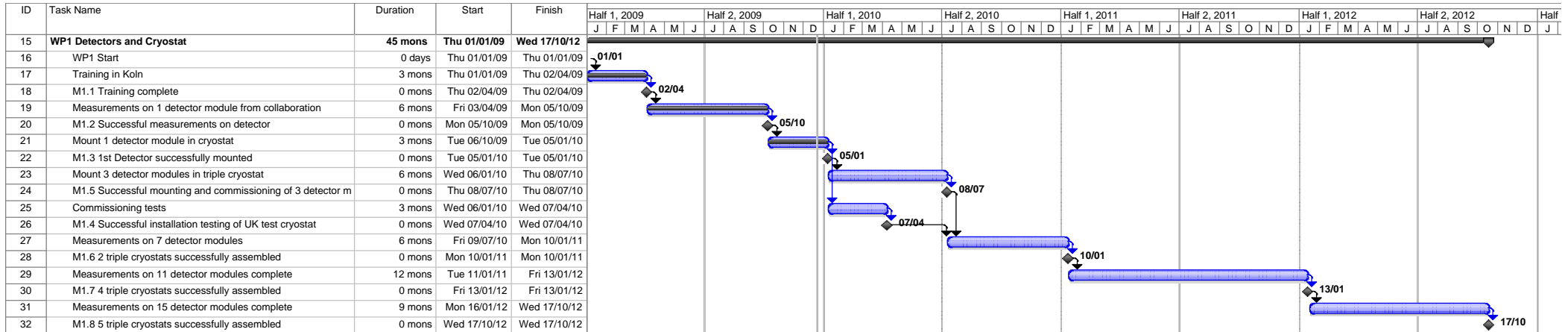
<u>Milestone no.</u>	<u>Work Package</u>	<u>Milestone</u>	<u>Target Date</u>	<u>Status</u>
M1.4	WP1	Successful installation testing of UK test cryostat	07 Apr 10	

**Table 3: Overall Milestone List**

<u>Mile- stone No.</u>	<u>Work Packag e</u>	<u>Milestone</u>	<u>As at June 09</u>	<u>As at Sept 09</u>	<u>Delay due to</u>		<u>Affects Critical Path?</u>	<u>See Note</u>
					<u>UK?</u>	<u>Others?</u>		
M1.1	WP1	Train Staff in Koln.	02 Apr 09	02 Apr 09				Complete
M1.2	WP1	Successful set of measurements on a detector capsule	05 Oct 09	05 Oct 09				Complete
M1.3	WP1	1 <sup>st</sup> Detector successfully mounted	05 Jan 10	05 Jan 10				Complete
M1.4	WP1	Successful installation testing of UK test cryostat	07 Apr 10	07 Apr 10				
M1.5	WP1	Successful mounting and commissioning of 3 detector modules into triple cryostats	8 July 10	8 July 10				
M1.6	WP1	2 triple cryostats successfully assembled	10 Jan 11	10 Jan 11				
M1.7	WP1	4 triple cryostats successfully assembled	13 Jan 12	13 Jan 12				
M1.8	WP1	5 triple cryostats successfully assembled	17 Oct 12	17 Oct 12				



(vii) Gantt Chart: Work Package 1



(viii) Earned Value Analysis: Work Package 1

ID	Task Name	BCWS	BCWP	ACWP	SPI	SV	CPI	CV	EAC	BAC	VAC
2	WP1 Detectors and Cryostat	£20,761.93	£20,761.93	£20,761.93	1	£0.00	1	£0.00	£129,139.87	£129,139.87	£0.00
3	WP1 Start	£0.00	£0.00	£0.00	0	£0.00	0	£0.00	£0.00	£0.00	£0.00
4	Training in Koln	£5,008.45	£5,008.45	£5,008.45	1	£0.00	1	£0.00	£5,008.45	£5,008.45	£0.00
5	M1.1 Training complete	£0.00	£0.00	£0.00	0	£0.00	0	£0.00	£0.00	£0.00	£0.00
6	Measurements on 1 detector module from collaboration FY2009	£6,474.34	£6,474.34	£6,474.34	1	£0.00	1	£0.00	£6,474.34	£6,474.34	£0.00
7	M1.2 Successful measurements on detector	£0.00	£0.00	£0.00	0	£0.00	0	£0.00	£0.00	£0.00	£0.00
8	Mount 1 detector module in cryostat	£9,279.14	£9,279.14	£9,279.14	1	£0.00	1	£0.00	£9,721.01	£9,721.01	£0.00
9	M1.3 1st Detector successfully mounted	£0.00	£0.00	£0.00	0	£0.00	0	£0.00	£0.00	£0.00	£0.00
10	Mount 3 detector modules in triple cryostat FY2009	£0.00	£0.00	£0.00	0	£0.00	0	£0.00	£8,162.52	£8,162.52	£0.00
11	Mount 3 detector modules in triple cryostat FY2010	£0.00	£0.00	£0.00	0	£0.00	0	£0.00	£9,995.67	£9,995.67	£0.00
12	M1.5 Successful mounting and commissioning of 3 detector modules into triple cryostats	£0.00	£0.00	£0.00	0	£0.00	0	£0.00	£0.00	£0.00	£0.00
13	Commissioning tests	£0.00	£0.00	£0.00	0	£0.00	0	£0.00	£1,665.08	£1,665.08	£0.00
14	M1.4 Successful installation testing of UK test cryostat	£0.00	£0.00	£0.00	0	£0.00	0	£0.00	£0.00	£0.00	£0.00
15	Measurements on 7 detector modules	£0.00	£0.00	£0.00	0	£0.00	0	£0.00	£19,991.35	£19,991.35	£0.00
16	M1.6 2 triple cryostats successfully assembled	£0.00	£0.00	£0.00	0	£0.00	0	£0.00	£0.00	£0.00	£0.00
17	Measurements on 11 detector modules complete FY2010	£0.00	£0.00	£0.00	0	£0.00	0	£0.00	£10,027.82	£10,027.82	£0.00
18	Measurements on 11 detector modules complete FY2011	£0.00	£0.00	£0.00	0	£0.00	0	£0.00	£28,766.71	£28,766.71	£0.00
19	M1.7 4 triple cryostats successfully assembled	£0.00	£0.00	£0.00	0	£0.00	0	£0.00	£0.00	£0.00	£0.00
20	Measurements on 15 detector modules complete FY2011	£0.00	£0.00	£0.00	0	£0.00	0	£0.00	£9,632.00	£9,632.00	£0.00
21	Measurements on 15 detector modules complete FY2012	£0.00	£0.00	£0.00	0	£0.00	0	£0.00	£19,694.93	£19,694.93	£0.00
22	M1.8 5 triple cryostats successfully assembled	£0.00	£0.00	£0.00	0	£0.00	0	£0.00	£0.00	£0.00	£0.00

4(b)                      Work Package 2                      **Interaction position determination  
using pulse-shape analysis**

**Leader:**                      Dr D.M. Cullen (Manchester)

**Institutes:**                      Manchester, Surrey and Liverpool

**(i)                      Brief summary of WP tasks:**

**Task 1: Detector Characterisation**

AGATA has detector modules of three different geometries. The position response of each individual detector type (geometry) to gamma rays must first be experimentally characterised in order to validate a model of the detector performance that is being developed using an electric-field simulation code (e.g. the MGS code). The characterisation process involves experimentally scanning a collimated source across the detector to locate interaction positions in three dimensions (to an accuracy of about  $1\text{mm}^3$ ) and collecting a statistically significant number of pulse shapes at each location (i.e. the time profile of the charge collection). This process is time consuming taking on average about 2 months per detector plus about 2 weeks setting up time. The collaboration has decided that at least three detectors of each geometry should be characterised in this way in order to determine any performance differences between the of detector modules, which are nominally the same.

**Task 2: 3D simulation code comparison with experimental detector characterisation**

The experimental data from the detector-characterisation scans (Task 1) will be compared with the predictions of a simulation code which aims to solve the Poisson equation for different detector geometries and predict the pulse shapes as a function of interaction position. There are a number of competing solutions including the MGS code which is being developed in Strasbourg. A Maxwell-3D simulation will be developed as part of this work. It is vital to the success of AGATA that reliable simulations are possible as the time taken to experimentally characterise all of the 180 planned detectors would be  $\sim 10$  years.

**Task 3: Pulse-shape algorithm development**

The analysis and interpretation of the data from the AGATA Demonstrator experiments rely on the pulse-shape versus position database information obtained from the characterisation scans. This work aims to get a reliable pulse-shape to position determination algorithm with sufficient accuracy over a range of positions and gamma-ray energies to allow initial analysis of the Legnaro data with a three-dimensional position determination accuracy of 4-5 mm. As the work continues and the algorithms are improved, an accuracy closer to 2 mm is expected. This will involve working with both the pulse-shape data base (Task 1) and the simulations (Task 2). This work is the responsibility of Manchester and Surrey who will concentrate on different aspects of the data from Legnaro.

**(ii)                      Activities during the past 6 months**

A WP2 Collaboration meeting took place between Liverpool, Manchester and Surrey (24<sup>th</sup> November 2009) to update each partner on progress and discuss future work. This information has been distributed to the international AGATA community through the EVO pulse-shape telephone meetings which take place every couple of weeks.

### Task 1: Detector Characterisation

After a delay due to a wiring problem with the first asymmetric detector “C001”, the repair to AGATA C001 was completed and the detector operational from 6th June 2009. A number of troubleshooting steps were followed with advice from the Cologne group and a large amount of experience has been built up in Liverpool. The performance of the detector was verified and a series of scans was performed. First a series of singles versus applied high-voltage scans was made to understand how the depletion of the detector changes with electric field and the effect this has on the pulse shapes at various positions. Figure 4(b) 1 below shows results for a 2000 V bias as a function of depth in the detector (ring number) from the front (ring 1).

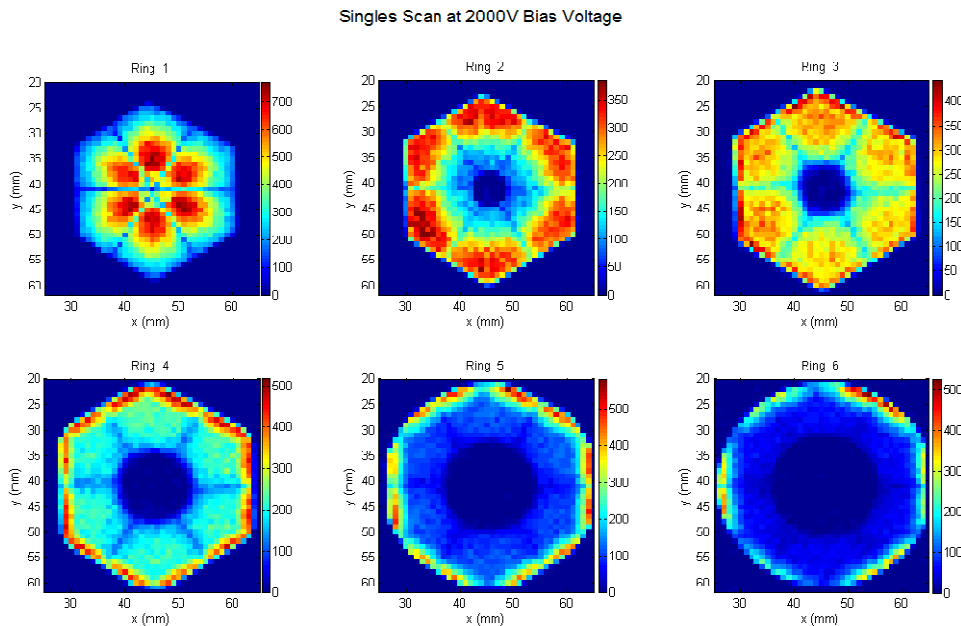


Figure 4(b) 1. Singles scans at 200V for different depths, indicated by ring numbers, ring 1 the front.

From these results, the fraction of the germanium which remained un-depleted was constructed as a function of various applied voltages. The figure below shows that a large fraction of detector remains un-depleted at 2000V. Conversely, at 4000V (500 V below the operating voltage) there is little evidence for un-depleted regions. These results were fed into the MGS simulation of the detector (task 2) and were required by the international AGATA community.

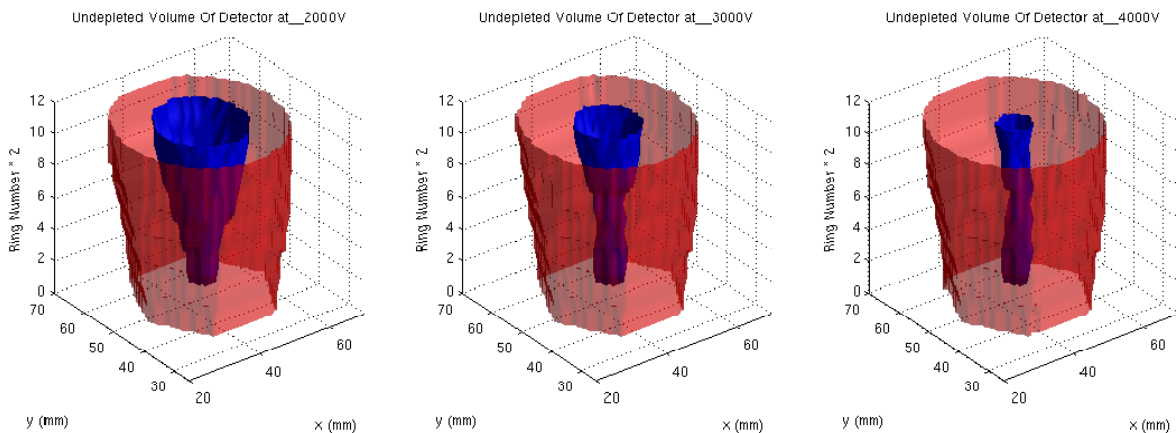


Figure 4(b)2 Indication of the non-depleted region (blue) of the crystal for different voltages.

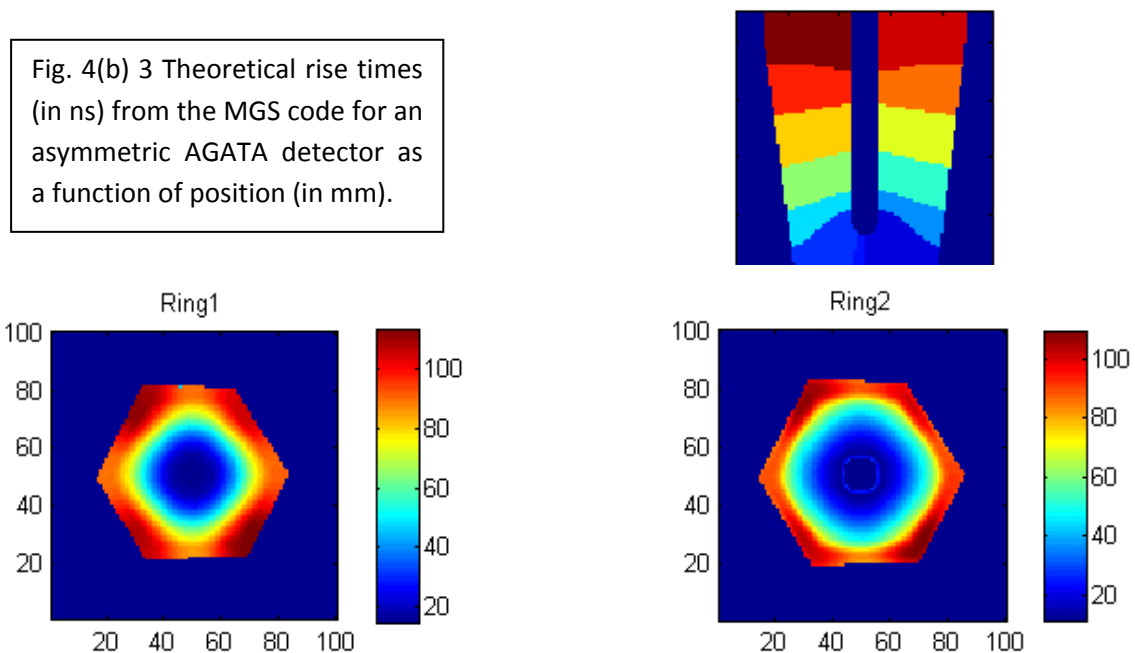
Figure 4(b)2 shows a 3D representation of the non-depleted region (blue) of the asymmetric AGATA detector from the scanned data as a function of applied high-voltage. Other scans (coincidence scan,  $^{137}\text{Cs}$  side scan,  $^{60}\text{Co}$  flood data) were performed to provide data for task 2 and these were complete in mid-November.

New Publications:

1. Dimmock et al., IEEE TRANSACTIONS ON NUCLEAR SCIENCE, VOL. 56, NO. 3, JUNE 2009
2. Dimmock et al., IEEE TRANSACTIONS ON NUCLEAR SCIENCE, VOL. 56, NO. 4, AUGUST 2009

### Task 2: 3D simulation code comparison with experimental detector characterisation

Theoretical MGS electric-field simulations have been performed for the three different AGATA detector shapes to understand the theoretical pulse shapes from the asymmetric detector scans. Particular focus has been placed on understanding the pulse shapes from the front part of the crystal where the electric field is more complex. So far, reasonable agreement has been found and the first triple detector pulse-shape database was delivered to Legnaro for use in the in-beam tests (task 3). The results obtained for the in-beam data look promising and these will be improved in task 3 as the pulse shapes versus position are improved with the detector scan data (task 1).



### Task 3: Pulse-shape algorithm development

Using data from the asymmetric detector scans, routines have been developed in Manchester to convert the Liverpool MIDAS data into “ROOT” format for ease of distribution to the international AGATA community. The data file sizes were reduced by a factor of two for the singles-scan data which was taken with the GRT-4 cards in Liverpool. The conversion routines were developed to handle single- or coincidence-scan data in raw and pre-sorted formats and can also perform event filtering and calibration. This conversion routine is available for the collaboration and was used to pre-sort the AGATA scan data for release to the international community.

Manchester has continued to work on the pulse shape algorithm development by installing and setting up Narval. Using these code developments, asymmetric scan data from Liverpool was directly read through the pre-processing and pulse-shape analysis as though it was data coming directly from

the AGATA in-beam experiments. The Narval processing also performs event filtering and calibration of the data. The next steps are to start to optimise the pulse shapes as a function of position. Various international AGATA EVO pulse-shape telephone meetings have been attended on a bi-weekly basis so that the international community is kept up-to-date with the developments and various in-beam experiments have been supported (WP4).

Whilst awaiting the scan data, the Surrey student has spent several weeks in Legnaro obtaining invaluable experience in performing source and in-beam experiments (WP4). He has analysed the in-beam data from an experiment in October with ancillary detectors. These ancillary detectors were used to better define the recoil angles for Doppler correction and gamma-ray tracking. He is in a good position to start to optimise and improve the various aspects of the Doppler correction and tracking by using asymmetric detector scan data from the pulse-shape analysis (task 1). In addition, the Surrey student has acquired the skills to perform simulation of experiments and this combined with the knowledge of pulse-shape optimisation will be used to improve simulation reliability in WP3.

### **(iii) Activities during the next 6 months**

WP2 collaboration meetings will continue to take place between Liverpool, Manchester and Surrey to update each partner on progress and future work. This information will continue to update the international AGATA community via the EVO pulse-shape telephone meetings.

#### **Task 1: Detector Characterisation**

The scan of the second asymmetric detector will begin as soon as it is available, expected to be Jan 2010. The development of the Fabio Crespi scanning method (Milan) will be completed and used to determine whether the method can speed up the scanning process for future detectors.

#### **Task 2 3D simulation code comparison with experimental detector characterisation**

The MGS electric-field simulation and pulse shapes from the first asymmetric detectors will be fully developed and a detailed comparison made with the experimental pulse shapes from the detector coincidence scans. One particular development area will be in the full implementation of the differential cross-talk algorithm and a comparison of the performance of MGS with the JASS codes will be made. These methods will be used to improve and optimise the pulse-shape database for use in future in-beam experiments. Maxwell 3D based simulations will be compared against the existing AGATA simulated databases.

#### **Task 3: Pulse-shape algorithm development**

Both data from the detector characterisation scans (task 1) and in-beam data will be analysed using the Narval framework in Manchester. The Narval framework allows input from the theoretical MGS calculated pulse shapes (task 2) to be used in the analysis of the data to optimise the pulse shape rise time and improve the position resolution (M2.5). This analysis will allow new PSA algorithms to be developed with improved position resolution and efficiency. These algorithms will be distributed to the international AGATA community for use in the in-beam experimental data collection by the international AGATA users. The improved position resolution will be used with the in-beam data Doppler broadening and tracking developments (Surrey) and the collimated beam reconstruction (M2.7). Position determination information will be passed to WP3 to allow the influence of the true position resolution of the GEANT simulation code to be investigated for some of the varied experimental scenarios the AGATA demonstrator will be used in.

(iv) Financial Statement: Work Package 2

Workpackage 2 Finance Summary (all figures in £k)															
	Approved (excluding contingency) (1)	Transfers (1a)		Actual spend in previous years (2)		Current year 2009/10		Latest estimate of future requirement (5)			Total		Variance		
		for each FY		2008/09		Year		2010/11		2011/12		2012/13		Actual (6-11a)	Projected (7-11a)
		2008/09	2009/10	2008/09	2009/10	to end Sept 09 (3)	spend this year (4)	2010/11	2011/12	2012/13	Actual spend (2+3) (6)	Projected spend (2+4+5) (7)			
<b>University Staff Effort Costs*</b>															
Liverpool University Effort (inc. student stipend)	36.83	7.07	4.85	11.74	23.48	34.33	1.05	0.19	16.59	43.90	-27.31	0.00			
Manchester University Effort	31.20	28.93	1.18	26.81	6.16	28.22	3.29	0.63	7.34	60.13	-52.80	0.00			
Surrey University Effort (inc. student stipend)	15.01		2.81	5.72	2.81	3.12	2.10	1.25	5.63	15.01	-9.39	0.00			
UWS Effort															
York University Effort (inc. student stipend)															
<b>University Sub-Total<sup>†</sup></b>	<b>83.05</b>	<b>36.00</b>	<b>8.84</b>	<b>20.71</b>	<b>56.02</b>	<b>45.67</b>	<b>6.44</b>	<b>2.07</b>	<b>29.55</b>	<b>119.04</b>	<b>-89.50</b>	<b>0.00</b>			
<b>STFC Lab Costs</b>															
Daresbury															
<b>STFC Lab Sub-Total</b>															
Student Fees Liverpool	2.36		0.74	0.45	0.89	0.50	0.23	0.00	1.19	2.36	-1.17	0.00			
Student Fees Surrey	2.63		1.32	1.32	0.64	0.33	0.21	0.13	2.64	2.63	0.01	0.00			
Equipment - Liverpool	8.94		3.47	1.16	5.47	5.47			4.62	8.94	-4.32	0.00			
Equipment - Manchester	8.94		3.90	0.39	5.04	5.04			4.29	8.94	-4.65	0.00			
Equipment - Surrey	8.94		3.36	0.39	8.18	8.18			4.12	8.94	-4.82	0.00			
<b>Equipment Total</b>	<b>26.81</b>		<b>8.12</b>	<b>4.90</b>	<b>18.69</b>	<b>18.69</b>			<b>13.03</b>	<b>26.81</b>	<b>-13.78</b>	<b>0.00</b>			
Travel Liverpool	1.94		0.51	1.29	0.88	0.88			1.79	1.94	-0.15	0.00			
Travel Manchester	1.69		0.54	0.54	1.18	0.41			0.64	1.70	-1.05	0.00			
Travel Surrey	1.35		0.17	0.64	0.72	0.46			0.81	1.35	-0.54	0.00			
<b>Travel Total</b>	<b>4.99</b>		<b>0.79</b>	<b>2.47</b>	<b>2.86</b>	<b>1.35</b>			<b>3.25</b>	<b>4.99</b>	<b>-1.73</b>	<b>0.00</b>			
Other Directly Allocated costs (eg consumables)	4.21		4.21		4.21										
Liverpool	8.39	3.27	0.85	3.30	6.60	4.06	0.10	0.05	4.15	11.66	-7.51	0.00			
Liverpool University Estates costs	11.38	10.88	2.29	1.47	7.87	10.78	1.16	0.17	3.76	22.27	-18.51	0.00			
Surrey University Estates costs	1.32		0.19	0.19	0.39	0.33	0.27	0.14	0.39	1.32	-0.93	0.00			
UWS Estates costs															
<b>York University Estates costs</b>	<b>14.16</b>		<b>3.33</b>	<b>4.96</b>	<b>14.86</b>	<b>15.17</b>	<b>1.53</b>	<b>0.36</b>	<b>8.29</b>	<b>35.25</b>	<b>-26.96</b>	<b>0.00</b>			
<b>University Estates costs total</b>	<b>21.09</b>		<b>3.33</b>	<b>4.96</b>	<b>14.86</b>	<b>15.17</b>	<b>1.53</b>	<b>0.36</b>	<b>8.29</b>	<b>35.25</b>	<b>-26.96</b>	<b>0.00</b>			
Liverpool University indirect costs	28.29	11.09	7.65	11.13	22.26	13.69	0.34	0.17	13.99	39.32	-36.33	0.00			
Manchester University indirect costs	30.94	29.51	6.21	3.97	21.34	29.37	3.13	0.46	10.18	60.35	-50.17	0.00			
Surrey University indirect costs	3.03		0.44	0.44	0.87	0.75	0.63	0.33	0.89	3.03	-2.14	0.00			
UWS indirect costs															
<b>York University indirect costs</b>	<b>40.54</b>		<b>9.51</b>	<b>15.95</b>	<b>44.47</b>	<b>43.66</b>	<b>4.10</b>	<b>0.96</b>	<b>25.05</b>	<b>102.69</b>	<b>-77.64</b>	<b>0.00</b>			
<b>University indirect costs</b>	<b>62.16</b>		<b>9.51</b>	<b>15.95</b>	<b>44.47</b>	<b>43.66</b>	<b>4.10</b>	<b>0.96</b>	<b>25.05</b>	<b>102.69</b>	<b>-77.64</b>	<b>0.00</b>			
<b>Total (Excluding VAT and WA)</b>	<b>207.28</b>	<b>90.70</b>	<b>32.65</b>	<b>50.35</b>	<b>142.63</b>	<b>106.68</b>	<b>12.51</b>	<b>3.52</b>	<b>83.00</b>	<b>297.99</b>	<b>-214.98</b>	<b>0.00</b>			
Working allowance	4.69		1.22	0.74	3.27	0.00	0.00	0.00	1.95	4.49	-2.74	-0.20			
VAT	17.50%														
<b>Total (including VAT &amp; WA)</b>	<b>211.98</b>	<b>90.70</b>	<b>33.87</b>	<b>51.08</b>	<b>145.91</b>	<b>106.68</b>	<b>12.51</b>	<b>3.52</b>	<b>84.96</b>	<b>302.48</b>	<b>-217.22</b>	<b>-0.20</b>			
<b>Rolling Grant Effort</b>															
Liverpool Rolling Grant Effort	15.64		4.74	1.88	3.76	3.27	2.75	1.13	6.62	15.65	-9.03	0.00			
Liverpool Rolling Grant Estates	3.86		1.51	0.44	0.88	0.73	0.56	0.18	1.95	3.86	-1.91	0.00			
Liverpool Rolling Grant Indirect	13.02		5.10	2.97	2.97	2.44	1.88	0.63	8.07	13.02	-4.95	0.00			
<b>Total Rolling Grant Cost</b>	<b>32.53</b>		<b>11.35</b>	<b>5.29</b>	<b>7.61</b>	<b>6.44</b>	<b>5.19</b>	<b>1.94</b>	<b>16.64</b>	<b>32.53</b>	<b>-15.88</b>	<b>0.00</b>			
<b>Total (Including VAT &amp; WA &amp; Rolling Grant)</b>	<b>244.50</b>	<b>90.70</b>	<b>45.22</b>	<b>56.37</b>	<b>153.52</b>	<b>113.12</b>	<b>17.70</b>	<b>5.45</b>	<b>101.60</b>	<b>335.01</b>	<b>-233.60</b>	<b>-0.20</b>			

Contingency (held by STFC)

\* Excluding workshop Allowance and VAT

† The University staff effort recorded in this table should be the 80% amount STFC pays, including academic time

- Use of columns:
- (1) = The amount approved by STFC
  - (1a) = This column should be used to show any variations between headings, for example when Working Allowance is used, the amount should appear as a debit in the WA row and then credited to the relevant row
  - (2) = The actual spend in previous financial years, by year
  - (3) = The actual spend in previous financial years, by year
  - (4) = The total projected spend for the current financial year, including any expenditure so far (ie actual spend this year plus predictions of remaining spend this year)
  - (5) = Projected spend for the remaining years
  - (6) = The actual spend so far
  - (7) = Projected spend over the whole duration of the project (ie actual spend so far plus predictions of remaining spend to project completion)
- The variance columns show the difference between the actual and projected amounts and the approved amount.

(v) Resource Usage: Work Package 2

WP2								
NAME	INSTITUTE	% FTE 2008/09	% FTE 2009/10	% FTE 2010/11	% FTE 2011/12	% FTE 2012/13	Total Effort	Effort Remaining
H Boston	Liverpool	0.070	0.090	0.025	0.010	0.005	0.200	0.040
Liverpool PDRA	Liverpool	0.000	0.600	0.400	0.000	0.000	1.000	0.400
Liverpool Student	Liverpool	0.150	0.225	0.125	0.050	0.000	0.550	0.175
D Cullen	Manchester	0.033	0.072	0.043	0.020	0.012	0.180	0.075
Manchester PDRA	Manchester	0.000	0.688	0.750	0.062	0.000	1.500	0.812
Z Podolyak	Surrey	0.010	0.020	0.025	0.030	0.015	0.100	0.070
Surrey Student	Surrey	0.250	0.400	0.200	0.125	0.075	1.050	0.400
<b>Rolling Grant</b>								
J Cresswell	Liverpool	0.025	0.050	0.050	0.050	0.025	0.200	0.125
M Norman	Liverpool	0.050	0.075	0.050	0.025	0.000	0.200	0.075

(vi) Milestones: Work Package 2

<u>Milestone No.</u>	<u>Work Package</u>	<u>Milestone</u>	<u>Target Date</u>	<u>Status</u>
M2.1	WP2	Theoretical Asymmetric Triple Cluster Basis set (MGS) delivered to Legnaro and used	01 April 09	Complete
M2.2	WP2	PDRA commenced work in Liverpool/Manchester	01 May 09	Complete
M2.3	WP2	Detector 1 available for scanning	24 June 09	Complete
M2.4	WP2	Detector 1: Basis set available collaboration.	18 Nov 09	Complete

<u>Milestone no.</u>	<u>Work Package</u>	<u>Milestone</u>	<u>Target Date</u>	<u>Status</u>
M2.5	WP2	Comparison of MGS electric field simulations with experimental pulse shapes complete and first interaction position algorithms ready	23 Dec 09	Aiming for end Feb 2010-ongoing
M2.6	WP2	Detector 1 : PSA development tests of collimated beam reconstructions and flood measurement.	22 Jan 10	Delayed to end March 2010 by detector scan delays.
M2.7	WP2	Detector 1 : PSA development tests of Compton reconstruction complete	25 Mar 10	
M2.8	WP2	Detector 2 : Basis data set available	01 Jan 10	Now expected April 2010
M2.9	WP2	Comparison of MGS electric field simulations with experimental pulse shapes	01 Feb 10	
M2.10	WP2	Preliminary analysis of AGATA Stage 0 data complete	2 Dec 09	Complete
M2.11	WP2	Preliminary Analysis of Phase 1 data complete	02 Feb 10	
M2.12	WP2	Detector 3 : Basis data set available	01 Mar 10	

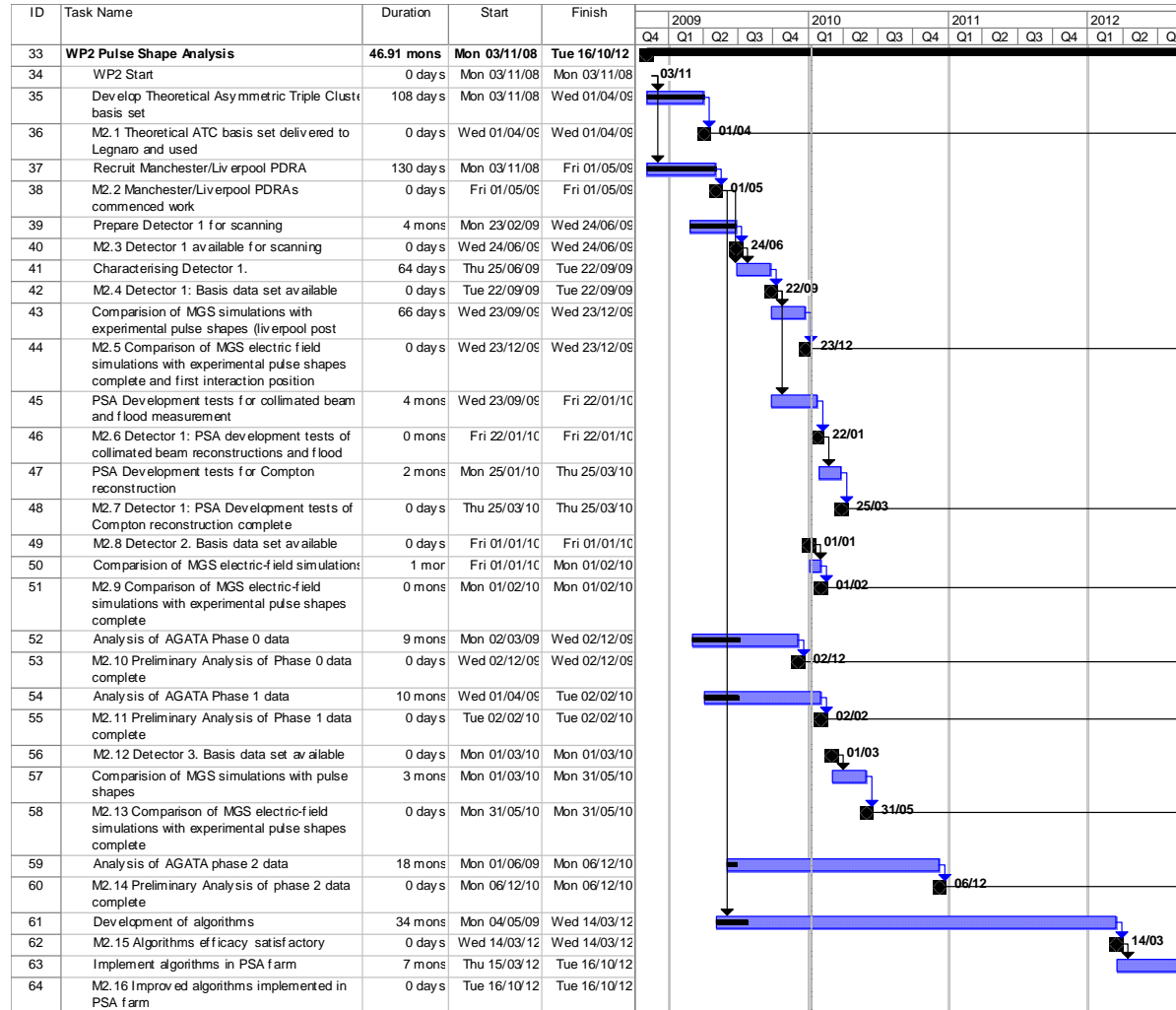
<u>Mile-stone No.</u>	<u>Work Package</u>	<u>Milestone</u>	<u>As at June 09</u>	<u>As at Sept 09</u>	<u>Delay due to</u>		<u>Affects Critical Path?</u>	<u>See Note</u>
					<u>UK?</u>	<u>Others?</u>		
M2.1	WP2	Theoretical Asymmetric Triple Cluster Basis set (MGS) delivered to Legnaro and used	01 April 09	01 April 09				Complete



M2.2	WP2	PDRA commenced work in Liverpool/Manchester	01 May 09	01 May 09				Complete
M2.3	WP2	Detector 1 available for scanning	24 June 09	24 June 09				Complete
M2.4	WP2	Detector 1: Basis data set available	22 Sept 09	18 <sup>th</sup> Nov 09	Y	Y		Complete
M2.5	WP2	Comparison of MGS electric field simulations with experimental pulse shapes complete and first interaction position algorithms ready	23 Dec 09	End Feb 10	Y	Y		
M2.6	WP2	Detector 1: PSA development tests of collimated beam reconstruction and flood measurement complete	22 Jan 10	End of March 2010	Y	Y		Due to detector 1 repair
M2.7	WP2	Detector 1: PSA Development tests of Compton reconstruction complete.	25 Mar 10	25 Mar 10				
M2.8	WP2	Detector 2: Basis data set available	1 Jan 10	End of April 2010	Y	Y		Due to detector 1 repair
M2.9	WP2	Comparison of MGS electric-	1 Feb 10	1 Feb 10				

		field simulations with experimental pulse shapes completed						
M2.10	WP2	Complete preliminary analysis of AGATA stage 0 data	2 Dec 09	2 Dec 09				Complete
M2.11	WP2	Preliminary Analysis of AGATA stage 1 data complete	2 Feb 10	2 Feb 10				
M2.12	WP2	Detector 3: Basis data set available. Start to develop in-beam algorithms	1 Mar 10	July 2010	Y	Y		Due to detector 1 repair
M2.13	WP2	Comparison of MGS electric-field simulations with experimental pulse shapes complete	31 May 10	Sept 2010	Y	Y		Due to detector 1 repair
M2.14	WP2	Preliminary analysis of AGATA stage 2 complete	6 Dec 10	6 Dec 10				
M2.15	WP2	Algorithm efficacy satisfactory	14 Mar 12	14 Mar 12				
M2.16	WP2	Improved Algorithms implemented in PSA farm	16 Oct 12	16 Oct 12				

(vii) Gantt Chart: Work Package 2



(viii) Earned Value Analysis: Work Package 2

ID	Task Name	BCWS	BCWP	ACWP	SPI	SV	CPI	SV	EAC	VAC
1	<b>WP2 Pulse Shape Analysis</b>	<b>£36,651.59</b>	<b>£36,181.49</b>	<b>£36,181.49</b>	<b>0.99</b>	<b>-£470.10</b>	<b>1</b>	<b>-£470.10</b>	<b>£135,471.05</b>	<b>-£0.01</b>
2	WP2 Start	£0.00	£0.00	£0.00	0	£0.00	0	£0.00	£0.00	£0.00
3	Develop Theoretical Asymmetric Triple Cluster basis set	£8,542.05	£8,542.05	£8,542.05	1	£0.00	1	£0.00	£8,542.05	£0.00
4	M2.1 Theoretical ATC basis set delivered to Legnaro and us	£0.00	£0.00	£0.00	0	£0.00	0	£0.00	£0.00	£0.00
5	Recruit Manchester/Liverpool PDRA	£0.00	£0.00	£0.00	0	£0.00	0	£0.00	£0.00	£0.00
6	M2.2 Manchester/Liverpool PDRA's commenced work	£0.00	£0.00	£0.00	0	£0.00	0	£0.00	£0.00	£0.00
7	Prepare Detector 1 for scanning	£1,800.25	£1,800.25	£1,800.25	1	£0.00	1	£0.00	£1,800.25	£0.00
8	Prepare Detector 1 for scanning	£3,258.31	£3,258.31	£3,258.31	1	£0.00	1	£0.00	£3,258.31	£0.00
9	M2.3 Detector 1 available for scanning	£0.00	£0.00	£0.00	0	£0.00	0	£0.00	£0.00	£0.00
10	Characterising Detector 1.	£1,826.20	£1,826.20	£1,826.20	1	£0.00	1	£0.00	£4,590.18	£0.00
11	M2.4 Detector 1: Basis data set available	£0.00	£0.00	£0.00	0	£0.00	0	£0.00	£0.00	£0.00
12	Comparison of MGS simulations with experimental pulse shapes (liverpool post doc)	£0.00	£0.00	£0.00	0	£0.00	0	£0.00	£3,174.92	£0.00
13	M2.5 Comparison of MGS electric field simulations with experimental pulse shapes complete and first interaction	£0.00	£0.00	£0.00	0	£0.00	0	£0.00	£0.00	£0.00
14	PSA Development tests for collimated beam and flood mea	£0.00	£0.00	£0.00	0	£0.00	0	£0.00	£4,257.96	£0.00
15	M2.6 Detector 1: PSA development tests of collimated beam reconstructions and flood measurement complete.	£0.00	£0.00	£0.00	0	£0.00	0	£0.00	£0.00	£0.00
16	PSA Development tests for Compton reconstruction	£0.00	£0.00	£0.00	0	£0.00	0	£0.00	£3,911.11	£0.00
17	M2.7 Detector 1: PSA Development tests of Compton reconstruction complete	£0.00	£0.00	£0.00	0	£0.00	0	£0.00	£0.00	£0.00
18	M2.8 Detector 2: Basis data set available	£0.00	£0.00	£0.00	0	£0.00	0	£0.00	£0.00	£0.00
19	Comparison of MGS electric field simulations with experimental pulse shapes	£0.00	£0.00	£0.00	0	£0.00	0	£0.00	£3,071.18	£0.00
20	Comparison of MGS electric field simulations with experimental pulse shapes	£0.00	£0.00	£0.00	0	£0.00	0	£0.00	£2,868.30	£0.00
21	M2.9 Comparison of MGS electric field simulations with experimental pulse shapes complete	£0.00	£0.00	£0.00	0	£0.00	0	£0.00	£0.00	£0.00
22	Analysis of AGATA Phase 0 data	£1,658.68	£1,658.68	£1,658.68	1	£0.00	1	£0.00	£1,658.68	£0.00
23	Analysis of AGATA Phase 0 data	£4,687.32	£4,525.39	£4,525.39	0.97	-£161.93	1	-£161.93	£7,542.32	£0.00
24	M2.10 Preliminary Analysis of Phase 0 data complete	£0.00	£0.00	£0.00	0	£0.00	0	£0.00	£0.00	£0.00
25	Analysis of AGATA Phase 1 data	£5,896.88	£5,896.88	£5,896.88	1	£0.00	1	£0.00	£11,793.76	£0.00
26	M2.11 Preliminary Analysis of Phase 1 data complete	£0.00	£0.00	£0.00	0	£0.00	0	£0.00	£0.00	£0.00
27	M2.12 Detector 3: Basis data set available	£0.00	£0.00	£0.00	0	£0.00	0	£0.00	£0.00	£0.00
28	Comparison of MGS simulations with pulse shapes	£0.00	£0.00	£0.00	0	£0.00	0	£0.00	£1,105.80	£0.00
29	Comparison of MGS simulations with pulse shapes	£0.00	£0.00	£0.00	0	£0.00	0	£0.00	£3,445.37	£0.00
30	M2.13 Comparison of MGS electric field simulations with experimental pulse shapes complete	£0.00	£0.00	£0.00	0	£0.00	0	£0.00	£0.00	£0.00
31	Analysis of AGATA phase 2 data	£3,958.03	£3,863.51	£3,863.52	0.98	-£94.52	1	-£94.52	£11,410.39	-£0.01
32	Analysis of AGATA phase 2 data	£0.00	£0.00	£0.00	0	£0.00	0	£0.00	£11,703.99	£0.00
33	M2.14 Preliminary Analysis of phase 2 data complete	£0.00	£0.00	£0.00	0	£0.00	0	£0.00	£0.00	£0.00
34	Development of algorithms	£5,023.87	£4,810.21	£4,810.21	0.96	-£213.66	1	-£213.66	£13,743.45	£0.00
35	Development of algorithms	£0.00	£0.00	£0.00	0	£0.00	0	£0.00	£24,324.36	£0.00
36	Development of algorithms	£0.00	£0.00	£0.00	0	£0.00	0	£0.00	£9,320.37	£0.00
37	M2.15 Algorithms efficacy satisfactory	£0.00	£0.00	£0.00	0	£0.00	0	£0.00	£0.00	£0.00
38	Implement algorithms in PSA farm	£0.00	£0.00	£0.00	0	£0.00	0	£0.00	£3,948.29	£0.00
39	M2.16 Improved algorithms implemented in PSA farm	£0.00	£0.00	£0.00	0	£0.00	0	£0.00	£0.00	£0.00

4(c) Work Package 3 **Experiment simulations and verification of tracking**

**Leader:** Prof. R. Wadsworth (York)

**Institutes:** York, UWS, Manchester, STFC Daresbury

Brief summary of WP tasks

- **Implementation of the experimental facilities into GEANT4** : The AGATA Geant4 simulation code which includes some ancillary detectors is to be installed at UK institutions. Additional ancillary detectors will be implemented during the commissioning phase at Legnaro and in preparation for the first campaign at GSI.
- **Verification of tracking algorithms:** The Orsay forward tracking code and MGT code from Legnaro are to be installed at UK institutions and their performance checked. Comparisons will be made between the performance of the two algorithms under different experimental conditions.
- **Simulation of key experiments at Legnaro:** This includes source simulations, the simulation of the commissioning experiments plus simulations of UK led experiments submitted to the Legnaro PAC.

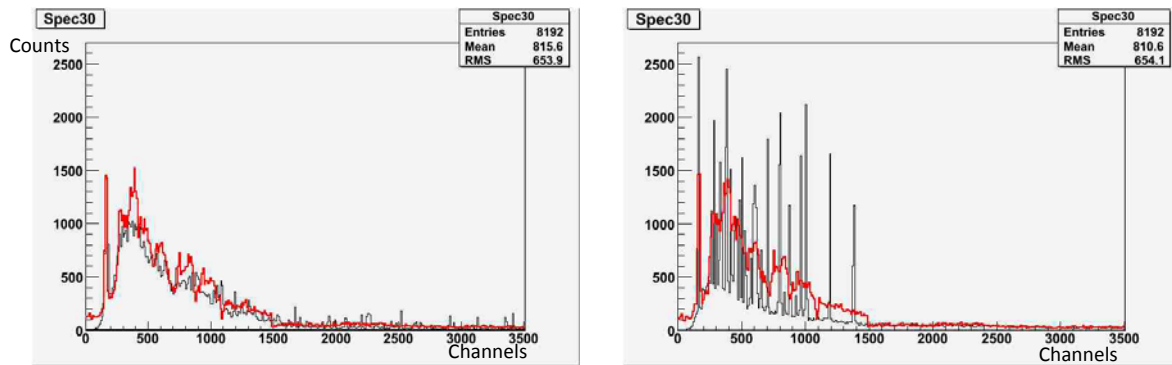
**Additional work requested for AGATA at GSI** : An urgent request for some resource to carry out this work was made by the UK project PI as a result of the recent decision to host AGATA at GSI following the Legnaro phase. This work involves the inclusion of the new Lund, York, Cologne Calorimeter (LYCCA) fragment detection array into the AGATA code and performing some physics simulations related to the GSI environment. As a part of the simulation for high recoil-velocity experiments at GSI, Doppler-broadening effects, the effect of the high levels of atomic background (primary and secondary Bremsstrahlung radiation) and the impact of high-energy particles (from beam interactions with tracking detectors) hitting the forward-angled detectors are to be investigated. This work will form part of milestone M3.5 of the work package.

**Activities during the past 6 months:**

The work carried out during the last 6 months was done to meet the milestone M3.3.

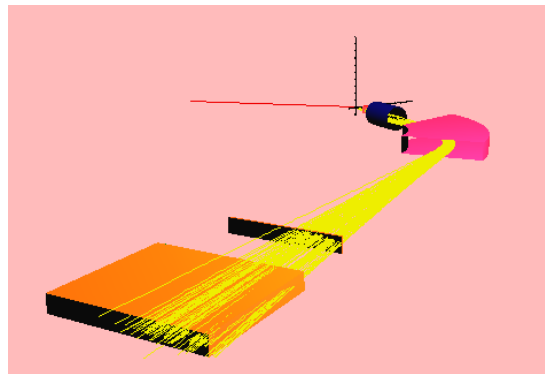
The four UK led experiments that are to be submitted to the January LNL PAC have been collected and the main requirements of the spokespersons have been identified. All four will utilise the deep-inelastic reaction mechanism. One of these will be a lifetime measurement, performed using a degrader foil, whilst other three are standard deep-inelastic experiments. All will use the AGATA demonstrator coupled with the PRISMA spectrometer and the DANTE detector. The reactions for the 3 standard experiments are (i)  $^{136}\text{Xe}$  at 750 MeV on a  $^{176}\text{Yb}$  target, (ii)  $^{86}\text{Kr}$  at 441 MeV on  $^{208}\text{Pb}$  target and (iii)  $^{82}\text{Se}$  at 435 MeV on  $^{192}\text{Os}$  target. The lifetime experiment involves a  $^{36}\text{S}$  beam impinging on a  $^{208}\text{Pb}$  target.

Grazing calculations (Wilkczinski plots –  $d\sigma/dE d\theta$ ) have been performed for the strongest reaction channels for the  $^{136}\text{Xe}$  experiment, by remotely running the Grazing code on a machine based in Legnaro. The connection to this machine has proved to be unreliable, hence the code is being installed at Daresbury and UWS. The event generator developed by collaborators in Milan, has been installed, tested and run with the Wilkczinski plots mentioned above as input. This event generator had to be modified so that the output could be used directly as input to the PRISMA simulation code. This modification involved a change of the coordinate frame system for the velocity vector of the projectile like fragment.



**Figure 4(c)1:** Results of the AGATA simulations: Left, gamma-rays from  $^{176-178}\text{Yb}$  nuclides and  $^{134-136}\text{Xe}$  partners without (red) and with (black) Doppler correction for Xe nuclides. Right, same as left, with Doppler correction for Yb nuclides.

Gamma rays have been also been added to the input file for the simulation code. The Gammaware software has been used to generate random gamma-cascades from the level scheme database. A program has been written to merge those gamma events with the projectile-like fragment events. Since the nuclei of interest in the experimental proposals are mainly target-like fragments, those fragments have also been included in the input file, together with their gamma rays. Thus, the input file for the simulations includes both projectile and target like fragments with their gamma-rays. The output of the AGATA simulations, after tracking, is shown in figure 4(c)1. The gamma energy spectra of Figure 1 will clean up significantly once a gate is applied on a specific nuclide in the PRISMA simulated data. Figure 4(c)2 illustrates preliminary PRISMA simulations for the Xe-like fragment nuclei.



**Figure 4(c)2:** Preliminary simulation of the Xe-like fragments detected in PRISMA

The output files from the AGATA simulation code and from the independent PRISMA code have been merged together in a binary file that is being analysed currently with the GASPPWARE application (which is the software used for the analysis of experimental data). The merged output file, together with some initial relevant spectra, will be delivered to each spokesperson for further detailed analysis prior to the submission of proposals in January 2010. Further support will also be provided to the spokespersons on request.

### Simulation of commissioning experiments:

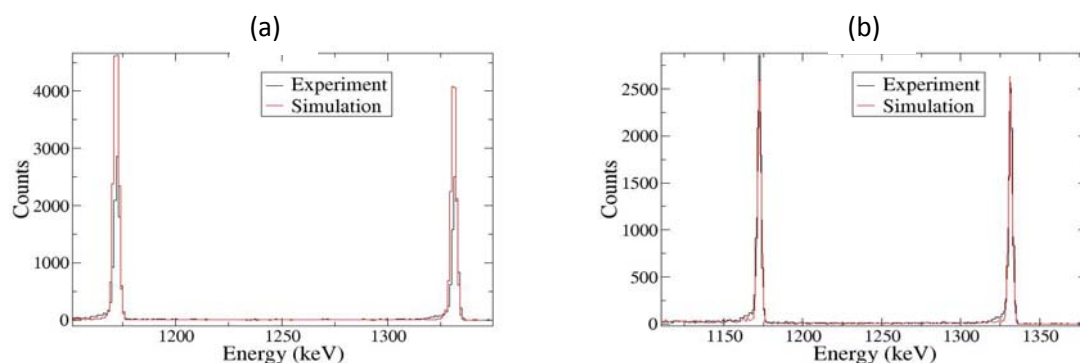
The four commissioning experiments performed to date include:

1.  $^{30}\text{Si}@70\text{MeV}+^{12}\text{C}$  fusion-evaporation reaction (Mar. 2009). Main goal: to obtain information on the position resolution provided by the PSA algorithms.
2.  $^{56}\text{Fe}@220\text{MeV}+^{197}\text{Au}$  Coulomb excitation reaction (Jul. 2009). Main goal: to test the trigger processor, performing coincidences with a charged particle detector.
3.  $^{32}\text{S}@130\text{MeV}+^{110}\text{Pd}$  fusion-evaporation reaction (Oct. 2009). Main goals: (i) to test the AGAVA interface in-beam, (ii) to test the response of the AGATA detectors to high-multiplicity events. The AGATA detectors, in this case two triple clusters, were operated in coincidence with an array of five  $\text{LaBr}_3$  scintillators and with a Si-strip detector.
4.  $^{58}\text{Ni}@235\text{MeV}+^{96}\text{Zr}$  (Dec 2009). Main goal: to test the coupling of AGATA with the PRISMA magnetic spectrometer and to evaluate the performance for multi-nucleon transfer reactions.

The simulation of the first commissioning experiment is being carried out by collaborators outside the UK. The simulation work for the others is in progress. An event generator for fusion-evaporation reactions exists and the work carried out on the event generator for the simulation of the UK deep inelastic experimental proposals will be used for the last and most complex commissioning experiment performed to date.

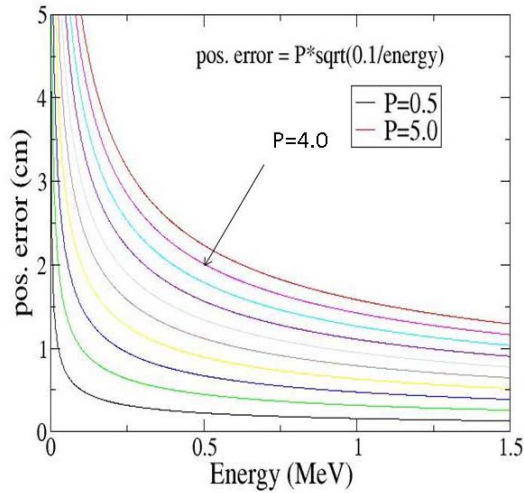
### Simulation of test runs with a $^{60}\text{Co}$ source:

The response of two triple clusters to gamma-rays emitted by a  $^{60}\text{Co}$  source has been simulated and compared with the experimental data collected in August 2009. The effect of the position smearing on gamma-ray tracking has been investigated by varying the parameter of the position error function (P) in the OFT tracking code. Table 1 shows the peak-to-total ratio obtained in the simulations for the different parameters (P), which is related to the position error function as defined in the figure embedded in Table 1, along with the experimentally determined value. Figure 3 shows the simulated gamma spectra using  $P=0.5$  and  $P=4$  and the experimental spectrum. It is clear that  $P = 4$  reproduces the measured spectrum and yields a peak-to-total in agreement with the data.

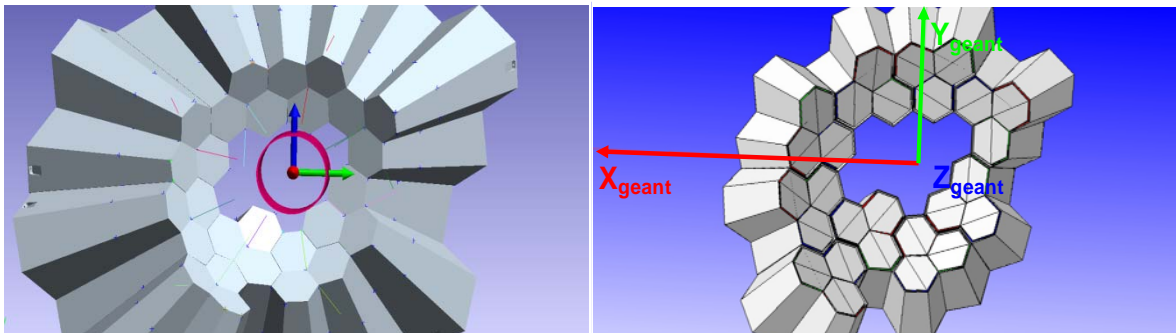


**Figure 4(c)3:** Comparison of experimental source spectra with simulations performed with (a) with  $P=0.5$ , (b) with  $P=4$

Table 1: The figure embedded in the table shows the position function as a function of energy for different values of the position parameter P. The table shows the peak to total values at 1332 keV for all the different values of P along with the experimental value (last column) determined from the source spectra.



Position error parameter P	P/T (Simul) %	P/T (Expt) %
0.5	67.98	
1.0	64.81	
1.5	60.28	
2.0	55.63	
2.5	51.03	
3.0	44.66	
3.5	41.49	
4.0	37.04	38.9
4.5	32.58	
5.0	28.51	



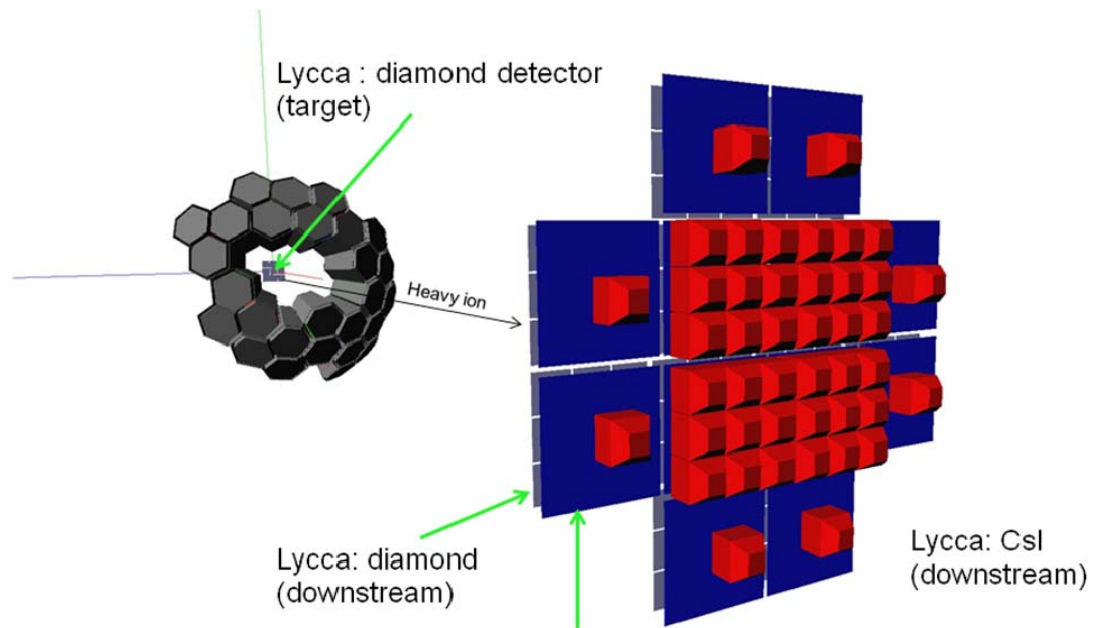
**Figure 4(c)4:** Conversion of CAD geometry (left) into Geant4 geometry (right) for AGATA at GSI.

#### Additional work considered for the future AGATA GSI campaign

This additional work was not specifically included earlier, but has recently (July 2009) been requested to be included in WP3 as it was felt to be important for the future UK science programme at GSI. The work to be carried out is comprised of:

- (i) Redefining the AGATA geometry for the GSI set-up through the conversion of the geometries obtained from the CAD tools into the Geant4 simulation code (see Fig. 4(c)4). This has been completed and test simulations performed with the newly defined geometry.
- (ii) The second aspect of this work is to include the new ancillary detector, LYCCA, in to the AGATA code. The LYCCA array will be used to track the fragments' direction as well as the interaction point. This information is used to reproduce the Doppler corrected gamma energies in the GSI environment, where recoil velocities are about 40-50% of the speed of light. This work is being carried out as part of Milestone M3.5 and is felt to be crucial as it will help decide the type of physics experiments to be done at GSI. This work to include LYCCA into the AGATA code has already been completed, since results from simulations are required in 2010. Fig. 4(c)5 shows a picture of the LYCCA array along with the AGATA S2 geometry produced from the simulation code.





**Figure 4(c)5:** The Lund, York, Cologne Calorimeter, LYCCA , and S2 AGATA geometry for GSI.

#### Activities during the next 6 months

Further simulations will be performed for AGATA at Legnaro as well as AGATA at GSI in the next six months. These will be done as part of milestones 3.4 and 3.5. The commissioning experiments carried out in 2009 will be simulated and compared with the analysed data as a part of this work. A realistic event generator for Coulomb-Excitation will need to be produced for some of this work. For the GSI environment the modified AGATA code with the new geometry for the GSI setup, including the LYCCA ancillary detector, will be used for simulations of the fast beam campaign. One experiment that is planned to be simulated at this time is the Coulomb excitation of  $^{50}\text{Fe}$  following its production via high energy fragmentation. This work will need an event generator for the reaction process to be constructed and it is planned to carry this out during this six month period.

(iv) Financial Statement: Work Package 3

Workpackage 3 Finance Summary (all figures in £k)

	Approved (excluding contingency) (1)	Transfers (1a)	Actual spend in previous years (2)		Current year 2009/10		Latest estimate of future requirement (5)			Total		Variance	
			for each FY		Actual Spend to end Sept 09 (3)	Projected spend this year (4)	2010/11	2011/12	2012/13	Actual spend (2+3) (6)	Projected spend (2+4+5) (7)	Actual (6-1-1a)	Projected (7-1-1a)
			2008/09	2009/10									
<b>University Staff Effort Costs*</b>													
Liverpool University Effort (inc student stipend)	38.65	-28.93	0.30	0.65	2.84		3.50	1.99	1.10	0.95	9.73	-8.77	0.00
Manchester University Effort	16.26	5.58	0.35	3.21	9.57		7.94	3.03	0.96	3.55	21.85	-18.29	0.00
Surrey University Effort (inc student stipend)	70.17	-7.42	9.09	10.22	16.43		18.44	12.31	6.49	19.31	62.75	-43.45	0.00
UWS Effort	125.09	-30.77	9.73	14.08	28.83		29.87	17.34	8.55	23.81	94.32	-70.51	0.00
York University Effort (inc student stipend)													
<b>University Sub-Total<sup>1</sup></b>													
STFC Lab Costs													
Daresbury	12.01		3.42	3.12	6.02		2.57	0.00		6.54	12.01	-5.48	0.00
Daresbury overhead	4.55		1.30	1.19	2.27		0.98	0.00		2.48	4.55	-2.07	0.00
<b>STFC Lab Sub-Total</b>	16.56		4.71	4.31	8.29		3.55	0.00		9.02	16.56	-7.54	0.00
Student Fees York	6.32		1.10	0.00	0.64		1.65	1.55	0.84	1.10	5.77	-5.22	-0.55
Equipment UWS	3.40		0.00	0.00	3.40					0.00	3.40	-3.40	0.00
Equipment York	1.41		0.00	0.00	1.41					1.41	1.46	-2.00	-1.94
<b>Equipment Total</b>	6.81		1.41	0.00	3.46					1.41	4.86	-5.40	-1.94
Travel York	7.45		0.72	0.70	3.63		2.26	0.84		1.42	7.45	-6.03	0.00
Travel Manchester	5.88		1.07	2.34	3.53		3.53	0.00		1.07	5.87	-4.81	0.00
Travel STFC	2.05		0.64	0.04	0.98		0.44	0.00		0.68	2.05	-1.37	0.00
<b>Travel Total</b>	15.38		1.36	1.81	6.95		6.23	0.84		3.17	15.37	-12.21	0.00
Other Directly Allocated costs (eg consumables)													
Liverpool University Estates costs	13.85	-10.89	0.57	0.14	0.77		0.93	0.45	0.23	0.72	2.96	-2.24	0.00
Manchester University Estates costs													
Surrey University Estates costs	3.43	1.10	0.36	0.75	1.85		1.51	0.63	0.19	1.11	4.53	-3.43	0.00
UWS Estates costs	15.18	-3.02	1.93	1.93	4.97		3.68	1.05	0.54	3.86	12.16	-8.30	0.00
York University Estates costs	32.46	-12.81	2.86	2.83	7.59		6.12	2.12	0.96	5.69	19.65	-13.97	0.00
<b>University Estates costs total</b>													
Liverpool University indirect costs	37.53	-29.51	1.55	0.99	2.10		2.53	1.21	0.63	1.94	8.02	-6.08	0.00
Manchester University indirect costs													
Surrey University indirect costs	13.20	4.68	0.55	3.06	7.78		6.40	2.41	0.74	3.61	17.88	-14.27	0.00
UWS indirect costs	30.06	-5.99	3.83	3.83	9.80		7.32	2.07	1.06	7.65	24.07	-16.42	0.00
York University indirect costs	80.79	-30.82	5.93	7.27	19.68		16.24	5.69	2.43	13.20	49.97	-36.77	0.00
<b>University indirect costs</b>													
<b>Total (excluding VAT and WA)</b>	283.41	-74.40	27.10	30.29	75.44		63.66	27.34	12.78	57.39	206.52	-151.61	-2.49
Working allowance													
VAT	1.19		0.25	0.00	0.61		0.00	0.00	0.00	0.25	0.85	-0.95	-0.34
	17.50%												
	15.00%												
<b>Total (including VAT &amp; WA)</b>	284.60	-74.40	27.34	30.29	76.04		63.66	27.54	12.78	57.64	207.37	-152.56	-2.83

Contingency (Held by STFC)

\* Excluding workshop Allowance and VAT

<sup>1</sup> The University staff effort recorded in this table should be the 80% amount STFC pays, including academic time

Use of columns:

- (1) = The amount approved by STFC
  - (1a) = This column should be used to show any virements between headings, for example when Working Allowance is used, the amount should appear as a debit in the WA row and then credited to the relevant row
  - (2) = The actual spend in previous financial years, by year
  - (3) = The actual spend in the current financial year up to the most recent quarter
  - (4) = The total projected spend for the current financial year, including any expenditure so far (ie actual spend this year plus predictions of remaining spend this year)
  - (5) = Projected spend for the remaining years
  - (6) = The actual spend so far
  - (7) = Projected spend over the whole duration of the project (ie actual spend so far plus predictions of remaining spend to project completion)
- The variance columns show the difference between the actual and projected amounts and the approved amount.

(v) Resource Usage: Work Package 3

WP3								
NAME	INSTITUTE	% FTE 2008/09	% FTE 2009/10	% FTE 2010/11	% FTE 2011/12	% FTE 2012/13	Total Effort	Effort Remaining
D Cullen	Manchester	0.033	0.072	0.043	0.020	0.012	0.180	0.075
Manchester PDRA	Manchester	0.000	0.046	0.050	0.004	0.000	0.100	0.054
C Chapman	UWS	0.015	0.045	0.045	0.045	0.030	0.180	0.120
UWS PDRA	UWS	0.000	0.250	0.200	0.050	0.000	0.500	0.250
R Wadsworth	York	0.036	0.072	0.072	0.072	0.036	0.288	0.180
Joshi	York	0.100	0.300	0.200	0.000	0.000	0.600	0.200
York Student	York	0.200	0.250	0.630	0.575	0.300	1.955	1.505
Marc Labiche	Daresbury	0.070	0.126	0.054	0.000	0.000	0.250	0.054

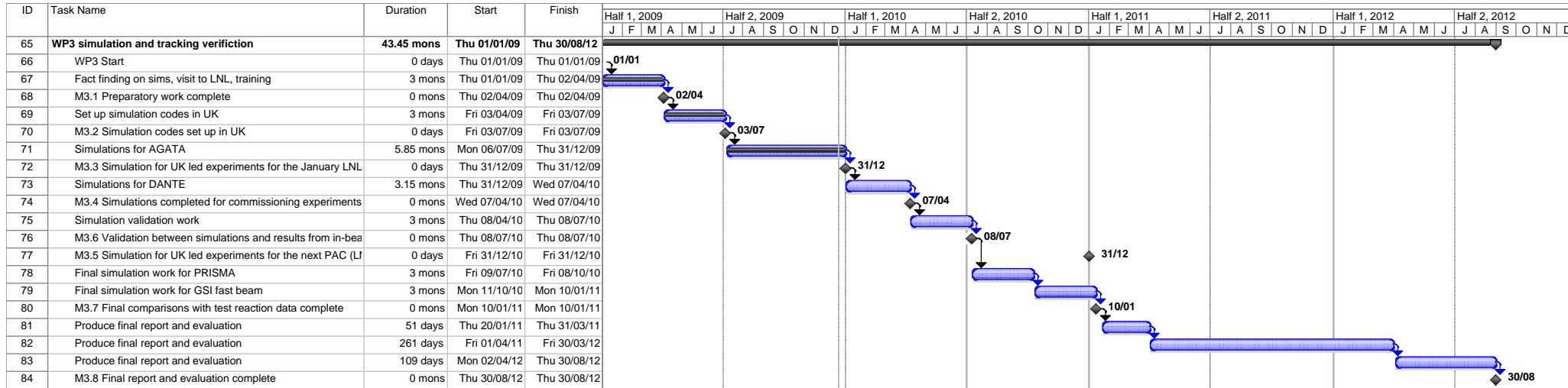
(vi) Milestones: Work Package 3

Milestone No.	Work Package	Milestone	Target Date	Status
M3.1	WP3	Preparatory work complete	02 April 09	Complete
M3.2	WP3	Simulation codes set up in the UK	05 July 09	Complete
M3.3	WP3	Simulation for UK led experiments for the January LNL PAC	31 Dec 09	Complete

Milestone no.	Work Package	Milestone	Target Date	Status
M3.4	WP3	Simulations completed for commissioning experiments	07 Apr 10	

Table 3: Overall Milestone List								
<u>Mile- stone No.</u>	<u>Work Package</u>	<u>Milestone</u>	<u>As at June 09</u>	<u>As at Sept 09</u>	<u>Delay due to</u>		<u>Affects Critical Path?</u>	<u>See Note</u>
					<u>UK?</u>	<u>Other s?</u>		
M3.1	WP3	Preparatory work complete	02 Apr 09	02 Apr 09				Complete
M3.2	WP3	Simulation codes set up in the UK	05 July 09	05 July 09				Complete
M3.3	WP3	Simulation for UK led experiments for the January LNL PAC	31 Dec 09	31 Dec 09				Complete
M3.4	WP3	Simulations completed for commissioning experiments	7 Apr 10	7 Apr 10				
M3.5	WP3	Simulation for UK led experiments for the next PAC (LNL or other)	31 Dec 10*	31 Dec 10*				
M3.6	WP3	Validation between simulations and results from in-beam data sets.	8 July 10	8 July 10				
M3.7	WP3	Final comparisons with test data complete	10 Jan 11	10 Jan 11				
M3.8	WP3	Final report and evaluation complete	9 May 12	9 May 12				

(vii) Gantt Chart: Work Package 3



(viii) Earned Value Analysis: Work Package 3

ID	Task Name	BCWS	BCWP	ACWP	SPI	SV	CPI	CV	EAC	BAC	VAC
1	<b>WP3 simulation and tracking verification</b>	<b>£28,093.92</b>	<b>£28,093.92</b>	<b>£28,093.93</b>	<b>1</b>	<b>£0.00</b>	<b>1</b>	<b>-£0.01</b>	<b>£107,644.33</b>	<b>£107,644.28</b>	<b>-£0.05</b>
2	WP3 Start	£0.00	£0.00	£0.00	0	£0.00	0	£0.00	£0.00	£0.00	£0.00
3	Fact finding on sims, visit to LNL, training	£12,448.52	£12,448.52	£12,448.52	1	£0.00	1	£0.00	£12,448.52	£12,448.52	£0.00
4	M3.1 Preparatory work complete	£0.00	£0.00	£0.00	0	£0.00	0	£0.00	£0.00	£0.00	£0.00
5	Set up simulation codes in UK	£9,512.61	£9,512.61	£9,512.61	1	£0.00	1	£0.00	£9,512.61	£9,512.61	£0.00
6	M3.2 Simulation codes set up in UK	£0.00	£0.00	£0.00	0	£0.00	0	£0.00	£0.00	£0.00	£0.00
7	Simulations for AGATA	£6,132.79	£6,132.79	£6,132.81	1	£0.00	1	-£0.01	£18,517.17	£18,517.13	-£0.04
8	M3.3 Simulation for UK led experiments for the J	£0.00	£0.00	£0.00	0	£0.00	0	£0.00	£0.00	£0.00	£0.00
9	Simulations for DANTE	£0.00	£0.00	£0.00	0	£0.00	0	£0.00	£9,251.10	£9,251.10	£0.00
10	M3.4 Simulations completed for commissioning e	£0.00	£0.00	£0.00	0	£0.00	0	£0.00	£0.00	£0.00	£0.00
11	Simulation validation work	£0.00	£0.00	£0.00	0	£0.00	0	£0.00	£8,918.00	£8,918.00	£0.00
12	M3.6 Validation between simulations and results f	£0.00	£0.00	£0.00	0	£0.00	0	£0.00	£0.00	£0.00	£0.00
13	M3.5 Simulation for UK led experiments for the n	£0.00	£0.00	£0.00	0	£0.00	0	£0.00	£0.00	£0.00	£0.00
14	Final simulation work for PRISMA	£0.00	£0.00	£0.00	0	£0.00	0	£0.00	£8,918.00	£8,918.00	£0.00
15	Final simulation work for GSI fast beam	£0.00	£0.00	£0.00	0	£0.00	0	£0.00	£8,918.00	£8,918.00	£0.00
16	M3.7 Final comparisons with test reaction data c	£0.00	£0.00	£0.00	0	£0.00	0	£0.00	£0.00	£0.00	£0.00
17	Produce final report and evaluation	£0.00	£0.00	£0.00	0	£0.00	0	£0.00	£6,574.24	£6,574.24	£0.00
18	Produce final report and evaluation	£0.00	£0.00	£0.00	0	£0.00	0	£0.00	£16,626.12	£16,626.12	£0.00
19	Produce final report and evaluation	£0.00	£0.00	£0.00	0	£0.00	0	£0.00	£7,960.57	£7,960.57	£0.00
20	M3.8 Final report and evaluation complete	£0.00	£0.00	£0.00	0	£0.00	0	£0.00	£0.00	£0.00	£0.00

#### 4(d) Work Package 4 **Support for setup and running of initial experiments**

**Leader:** Dr. J. F. Smith (University of the West of Scotland)

**Institutes:** UWS, Liverpool, Manchester, Surrey, York, and STFC Daresbury Laboratory

##### **(i) Brief summary of WP tasks**

In the initial phase of the AGATA project, five triple-clusters will be configured together at the Legnaro National Laboratory in Italy to form the AGATA Demonstrator. The Demonstrator will be used to show the validity of the pulse-shape analysis and tracking algorithms in real time, under real experimental conditions. Initially, tests will be carried out with radioactive sources and with simple in-beam reactions. Following these initial tests, commissioning experiments will be carried out, using the Demonstrator in conjunction with PRISMA. This will be followed by a physics campaign, in which the Demonstrator will be used in real experiments for a period of around eighteen months.

The purpose of Work Package 4 is to carry out the setup and installation of the AGATA detectors at Legnaro, and to run the initial source and in-beam tests and to demonstrate the performance of AGATA in the commissioning experiments. The set-up and running of the initial experiments is a central part of the AGATA project which ties together the outputs of some work packages and provides input for others, specifically: WP2, WP3, WP5, and WP6. All of the collaborating UK institutions are participants of this work package. There is a close association between the PDRA/EO and student effort on this work package with that of WP1, WP2, and WP3.

##### **Tasks**

- Installation of AGATA detectors as the AGATA Demonstrator at Legnaro National Laboratory.
- Running of the test experiments, with sources and in-beam, plus other commissioning experiments which are essential for the future physics programmes.
- Use the output of Work Package 2 (identification of interaction positions) and the tracking algorithms with real in-beam data to optimise the analysis packages.

##### **Outputs**

- Installation and commissioning of the AGATA Demonstrator at Legnaro National Laboratory.
- Experience of processing and analyzing data from AGATA with different reactions conditions i.e. reactions with different gamma-ray multiplicities, gamma-ray energies, recoil velocities, event rates and with varying gamma-ray backgrounds (radioactive-ion beam experiments).
- Dissemination of experience to the UK and international nuclear-physics communities via workshops and conferences.
- Comparison of the performance of AGATA in source and in-beam experiments with experimental simulations (input for Work Package 3).

##### **(ii) Activities during the past 6 months**

The UK effort in the initial experiments has been co-ordinated by the Work Package Leader (Smith) in consultation with Dr. Enrico Farnea who is the AGATA Technical Coordinator at Legnaro. With the exception of the Project Student at York, all of the UK PDRAs and Project Students, with tasks on this work package, were in place before the present reporting period began. The student at York was appointed in September 2009.

As stated in the previous Oversight Committee report, the ongoing developments in the set-up of the AGATA Demonstrator have been designated different stages, as listed below.

<i>Stage 0</i>	Test of a triple cluster with a radioactive source
<i>Stage 1</i>	In-beam test of a triple cluster
<i>Stage 2</i>	In-beam test of a triple cluster with a simple ancillary detector
<i>Stage 3</i>	In-beam test of multiple (three) triple clusters
<i>Stage 4</i>	In-beam test of triple clusters with the PRISMA spectrometer

At the July 2009 PAC meeting at Legnaro National Laboratory, thirteen days of beam-time were awarded to the AGATA Collaboration, for commissioning of Demonstrator. The thirteen days were divided into three periods, and three commissioning experiments were scheduled in October, November, and December. Thus, to date, seven commissioning experiments have now been carried out. These experiments are summarized in the table below; some experimental details are given such as the number of asymmetric triple clusters (ATCs).

<i>Week</i>	<i>Dates (2009)</i>	<i>Experimental details</i>	<i>Stage</i>
8	16/2 – 20/2	Radioactive source test (one ATC)	0
12	16/3 – 20/3	In-beam test of a triple cluster (with one ATC)	1
22	30/5 – 1/6	“Parasitic test” – problems with beam	1,2
27	29/6 – 5/7	In-beam test with two Ge crystals and DANTE	2,3
43	22/10 – 26/10	In-beam test with two ATCs and Si plus LaBr <sub>3</sub> using AGAVA	2,3
46	13/11 – 16/11	In-beam test of two ATCs with PRISMA	3,4
49	3/12 – 7/12	In-beam test of two ATCs with PRISMA	3,4

Experiments covering Stage 0 and Stage 1, in Week 8 and Week 12, were described in the previous report (July 2009). The so-called “parasitic” test in Week 22 attempted to exploit a gap in the Legnaro beam-time schedule – that is, this was not an officially scheduled AGATA commissioning experiment. Due to problems with the beam, this “parasitic” test was not fruitful. The remaining commissioning experiments, covering Stages 2, 3 and 4, have been carried out in the present reporting period, and are described below.

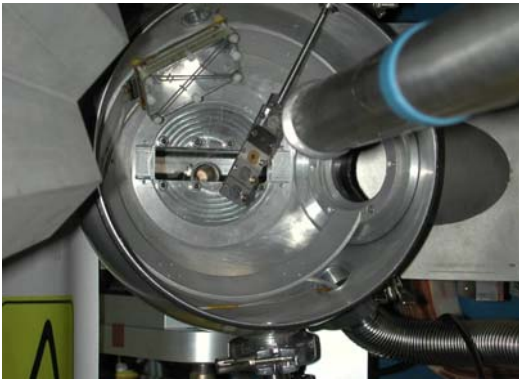
***In beam test of a triple cluster with a simple ancillary detector [Stage 2] (29<sup>th</sup> June – 5<sup>th</sup> July 2009)***

The first in-beam test of a triple cluster with an ancillary detector was carried out in Week 27 (29th June - 5th July 2009). The primary purposes of the experiment were (i) to prove the feasibility of coupling a simple ancillary detector to the AGATA Demonstrator and (ii) to test the digital-trigger processor, which validates the events and assigns the event number. In this case the ancillary detector was one of the multi-channel plates (MCP) of the DANTE array. The experiment studied the Coulomb excitation of <sup>56</sup>Fe.

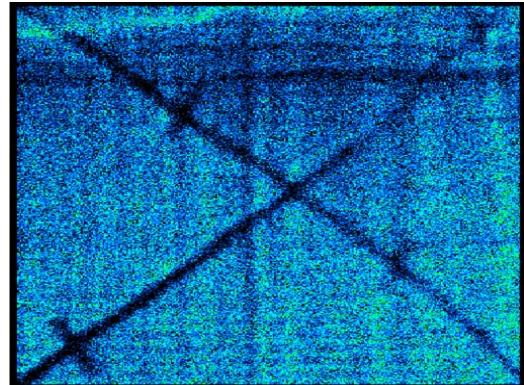


**Figure 4(d)1** The experimental set-up in the Week 27 AGATA commissioning experiment. The multi-channel plate (MCP) detector of DANTE can be seen inside the target chamber.

The experimental set up is shown in Figures 4(d)1 and 4(d)2. A beam of  $^{56}\text{Fe}$  at 220 MeV from the Legnaro tandem accelerator was incident on a thin target of  $^{197}\text{Au}$ . The goal of the experiment was to measure the resolution of the  $2^+ \rightarrow 0^+$  transition (847 keV) in  $^{56}\text{Fe}$ . The scattered  $^{56}\text{Fe}$  ions were detected by the DANTE MCP, facilitating a kinematic Doppler correction. At the time of this experiment the AGAVA interface (AGATA VME ancillary adapter) was not available: signals from the MCP (X, Y, and time) were therefore acquired through one of the AGATA digitizers. For this reason, only two of the three crystals of the AGATA ATC were acquired. Coincidences between AGATA and MCP signals were selected by the AGATA real-time digital trigger.



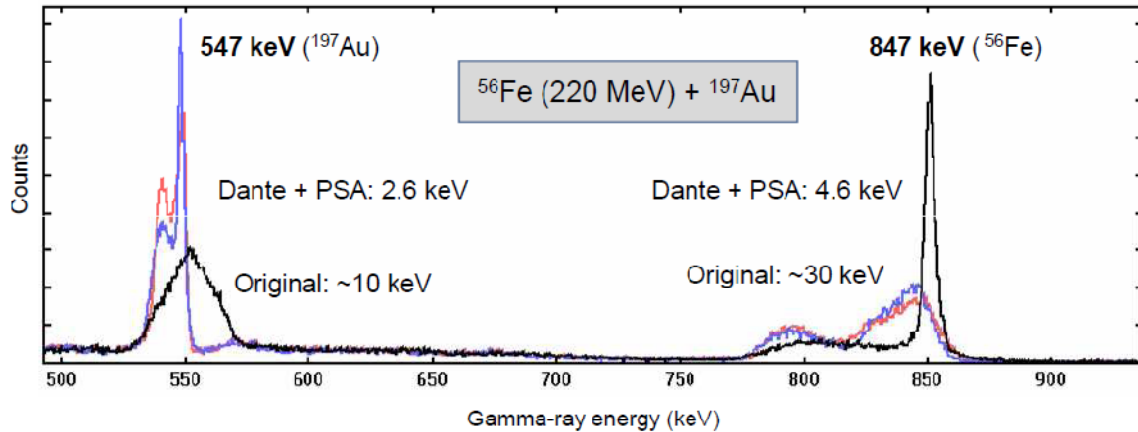
**Figure 4(d)2** A close-up of the target chamber showing the DANTE MCP and the target ladder.



**Figure 4(d)3** The distribution of interactions in the DANTE MCP. The diagonal-cross mask can be seen in the photographs [7(d)1 and 7(d) 2].

The analysis of the data from the AGATA germanium detectors was performed online using the NARVAL farm, but the analysis of DANTE data was carried out off line, as the online analysis code was not ready at the time.





**Figure 4(d)4** Spectra from the Week-27 commissioning experiment: Coulomb excitation of a 220 MeV  $^{56}\text{Fe}$  beam on a  $^{197}\text{Au}$  target. The improvement in resolution with pulse-shape analysis and with the kinematic-correction facilitated by DANTE is clearly apparent.

A spectrum from the experiment is shown in Figure 4(d)4. The black-line shows the kinematic correction applied for the beam, and the blue line, for the target recoils. The improvement in resolution when carrying out pulse-shape analysis together with a kinematic Doppler correction afforded by the DANTE MCP is obvious. The kinematic correction demonstrates the validity of the gamma-recoil correlations. Use of the AGATA digitizer to acquire MCP data was not ideal due to the fast rise times of the signals compared with Ge detector signals. This was, however, a temporary measure in the absence of the AGAVA interface.

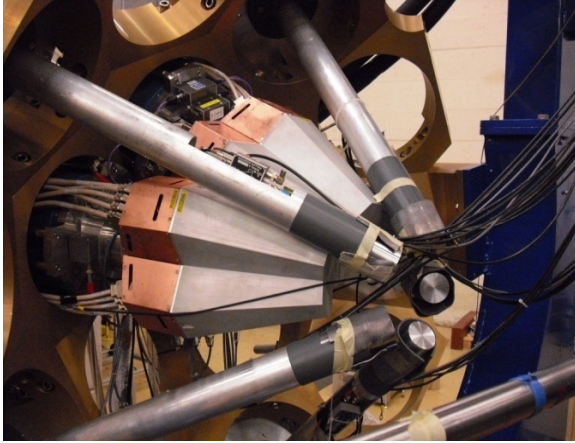
#### ***In beam test of multiple triple-clusters [Stage 2 and Stage 3] (22nd – 26th October 2009)***

The commissioning run in Week 43 (22nd – 26th October 2009) had several goals which can be summarized as follows.

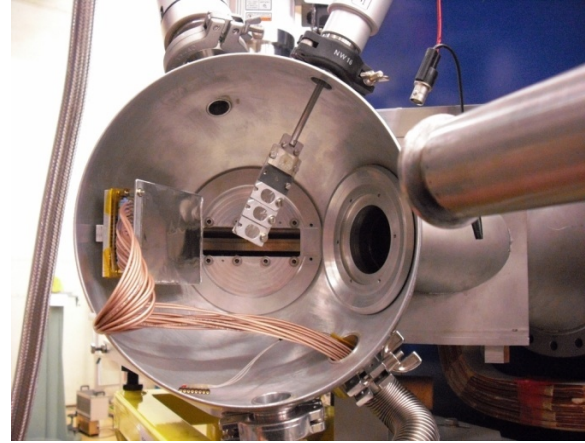
- To test two asymmetric-triple clusters in coincidence – this was the first experiment in which two triple clusters were used together.
- To couple the triple-clusters to simple ancillary devices using the AGAVA interface (AGAVA is the “AGATA ancillary VME adapter”) – this was the first experiment in which AGAVA was used in experimental conditions.
- To test the triple clusters with high-multiplicity gamma-ray data.
- To test the digital-trigger processor with two partitions: AGATA and AGAVA.

In order to achieve a high gamma-ray multiplicity, a well-studied heavy-ion fusion evaporation reaction was used. A beam of  $^{32}\text{S}$  at 135 MeV, was incident upon targets of  $^{110}\text{Pd}$ , producing a  $^{142}\text{Sm}$  compound nucleus. The most intense reaction products were expected to be  $^{138}\text{Sm}$  ( $4n$  evaporation),  $^{138}\text{Pm}$  ( $p3n$ ), and  $^{138}\text{Nd}$  ( $2p2n$ ). These nuclei have previously been well studied at high spins, for example by E. S. Paul et al., in Physical Review C 36, 2380 (1987).

Two AGATA triple-clusters were used in conjunction with five  $\text{LaBr}_3$  scintillators and a 300- $\mu\text{m}$  thick silicon detector with 16 resistive strips. The  $\text{LaBr}_3$  scintillators were mounted in the AGATA support frame (at positions 5, 7, 9, 11, and 13) – as shown in Figure 4(d)5. (The AGATA triple clusters were mounted at positions 2 and 3). The silicon detector was mounted inside the AGATA target chamber, as shown in Figure 4(d)6, with a central polar angle of  $\theta=40^\circ$ .

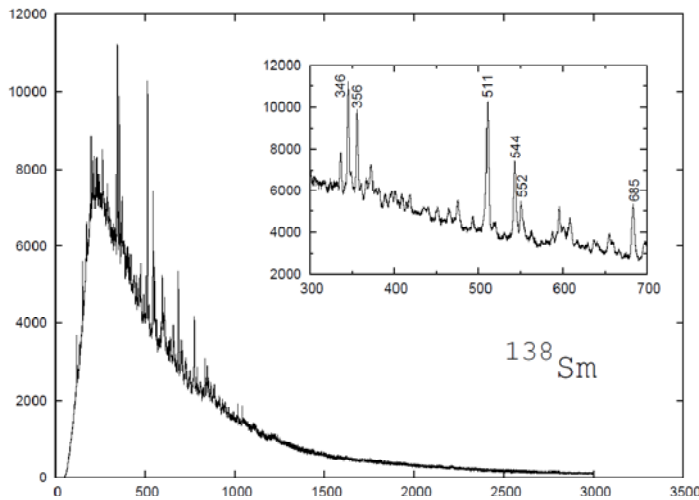


**Figure 4(d)5** The experimental set-up for the Week-43 test. The two AGATA ATCs can be seen together with the five LaBr<sub>3</sub> scintillators.



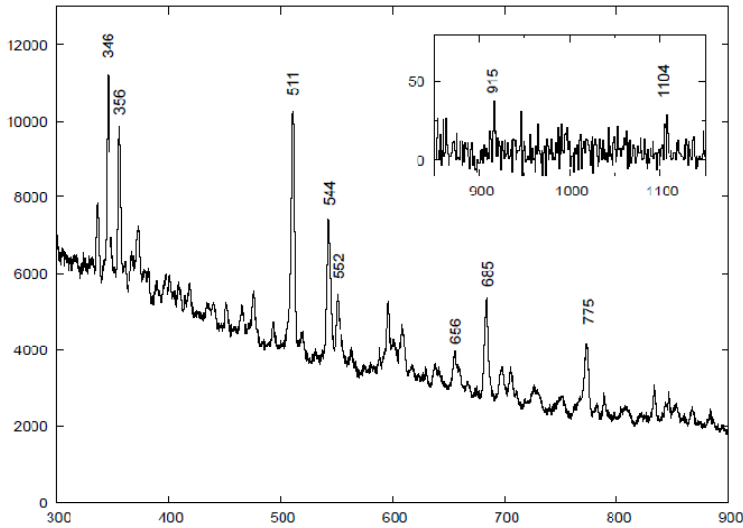
**Figure 4(d)6** A close-up of the target chamber for the Week-43 test. The silicon detector can be seen on the left-hand side of the photograph.

The five LaBr<sub>3</sub> detectors and one of the resistive strips from the silicon detector were acquired through AGAVA. Data were collected with thin targets ( $\sim 500 \mu\text{g}/\text{cm}^2$ ) both backed ( $8 \text{ mg}/\text{cm}^2$  of gold) and unbacked, and with several different trigger conditions (with different gamma-ray multiplicities). The majority of the data were collected with a trigger of either: (i) AGAVA (ancillary) plus one Ge crystal or (ii) two Ge crystals.



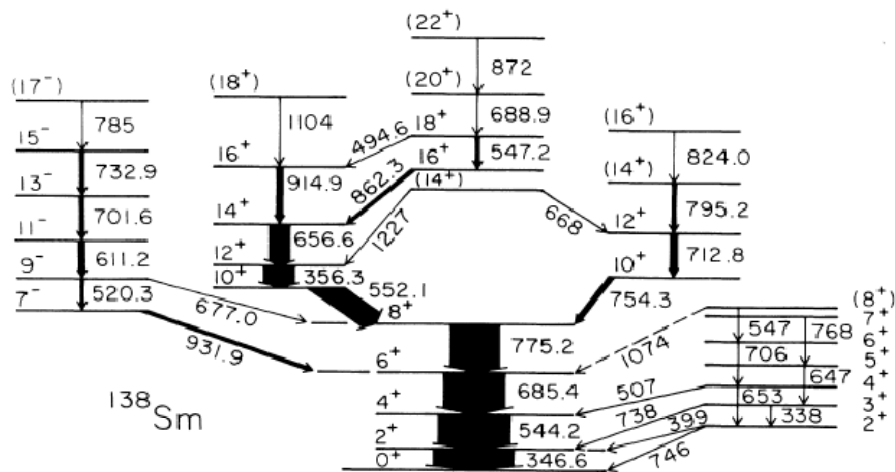
**Figure 4(d)7** A representative spectrum acquired from the fusion evaporation reaction  $^{32}\text{S}$  at 135 MeV +  $^{110}\text{Pd}$ .

A preliminary spectrum from the experiment is shown on the left. The spectrum is from a single germanium crystal. The recoil velocity was determined experimentally to be  $\beta=0.02$ , and the Doppler correction was carried out by assuming that all recoils go forwards at  $\theta=0^\circ$ . The inset shows the spectrum expanded around the 300 to 700 keV region. All of the labelled peaks (apart from the 511-keV  $e^+e^-$  peak) are attributed to transitions in  $^{138}\text{Sm}$ , produced in the  $^{110}\text{Pd}(^{32}\text{S},4n)$  reaction.

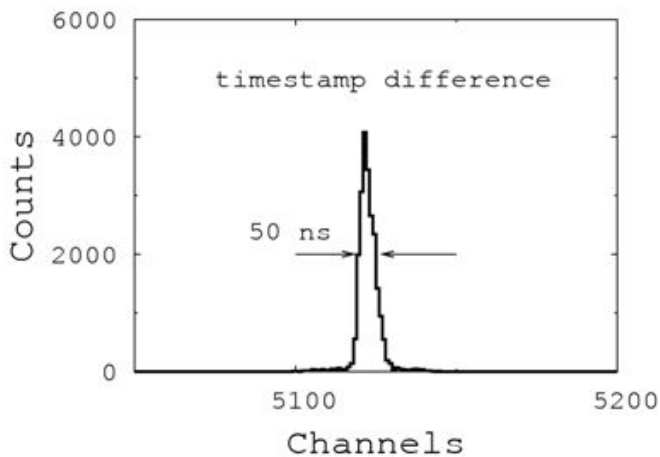


The inset of Figure 4(d)8 shows part of a coincidence spectrum gated on the 347-keV  $2^+ \rightarrow 0^+$  transition in  $^{138}\text{Sm}$ . The spectrum is taken from a  $\gamma\gamma$  correlation matrix constructed from all six germanium crystals used in the experiment. The level scheme of  $^{138}\text{Sm}$  is shown in Figure 4(d)9. The 1104-keV  $18^+ \rightarrow 16^+$  and the 915-keV  $16^+ \rightarrow 14^+$  transitions can clearly be seen in the inset.

**Figure 4(d)8** The spectrum acquired from one germanium crystal, highlighting transitions in  $^{138}\text{Sm}$ . The inset shows a coincidence spectrum, gated on the  $2^+ \rightarrow 0^+$  transition in  $^{138}\text{Sm}$ .



**Figure 4(d)9** The level scheme of  $^{138}\text{Sm}$  from E.S. Paul et al., Physical Review C **36**, 2380 (1987).

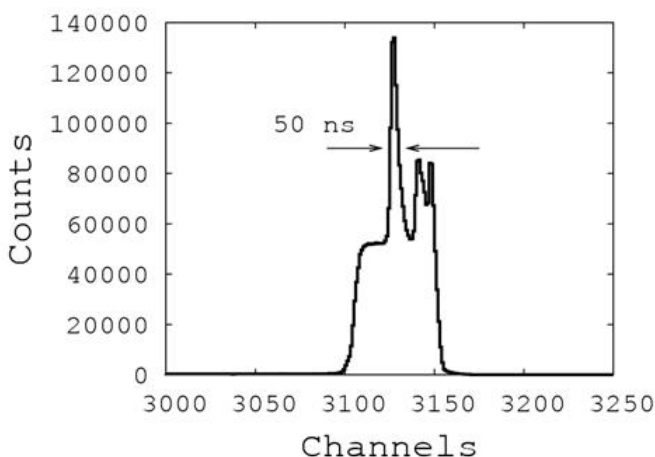


**Figure 4(d)10** The timestamp difference between one of the six Ge crystals and all the LaBr scintillators detectors.

The synchronization between AGATA and AGAVA has been evaluated in terms of the timestamp differences after merging. An overall time resolution of about 50 ns (as shown in Figure 4(d)10) was obtained between each of the crystals and all of the scintillators.

***In beam test of two triple-clusters with the PRISMA spectrometer [Stage 3 and 4] (13th – 16th November & 3rd – 7th December 2009)***

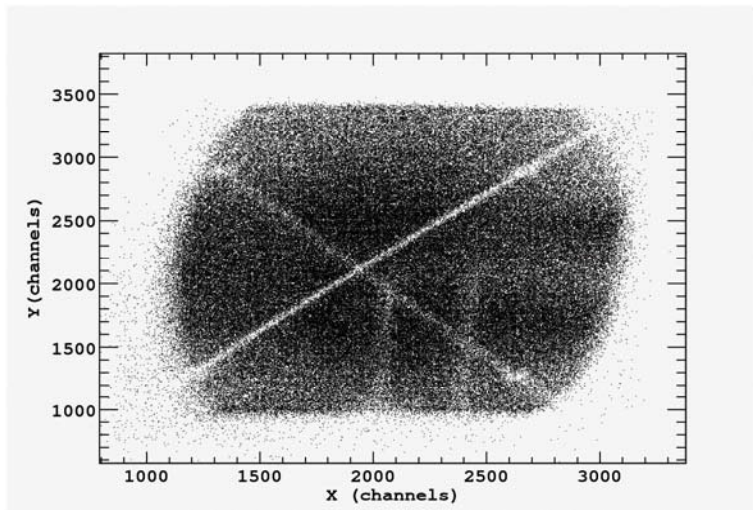
Two in-beam test experiments have been performed in order to test the coupling of the AGATA to the PRISMA magnetic spectrometer via the AGAVA interface. Both of these test experiments used the same beam-and-target combination: a  $^{58}\text{Ni}$  beam at 235 MeV incident upon a thin  $^{96}\text{Zr}$  target. Following multi-nucleon transfer reactions at the target position, the beam like products were transported to the focal plane of PRISMA where they were identified by Z and A identification in the array of MWPCs and ionization chambers. The first of these tests took place in November 2009 (Week 46). The set-up consisted in two triple clusters plus a DANTE MCP and the PRISMA magnetic spectrometer both acquired via standard VME electronics and coupled through the AGAVA interface.



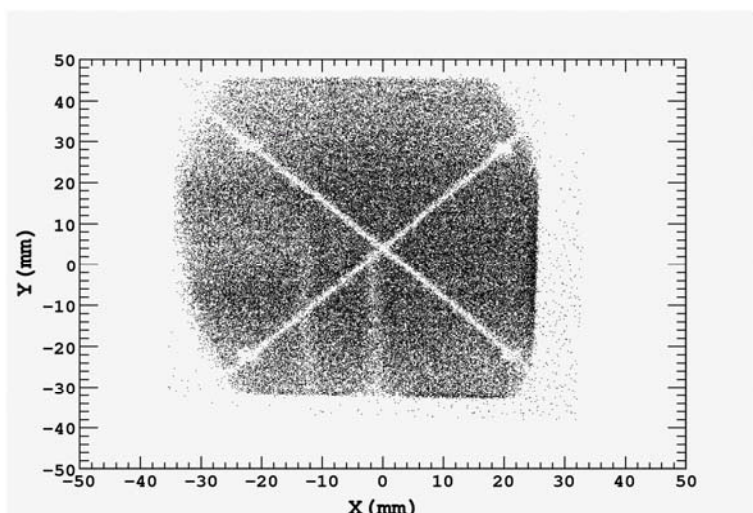
**Figure 4(d)11** The timestamp difference between one of the six Ge crystals and DANTE or PRISMA. Ge-DANTE coincidences correspond to the larger peak on the left, and Ge-PRISMA coincidences correspond to the smaller peak on the right.

The experiment in week 46 suffered from several technical problems, resulting in only a small amount of useful data. However, the data collected were sufficient to demonstrate that the coupling of AGATA to PRISMA through the AGAVA interface is working. The synchronization between AGATA and PRISMA, and between AGATA and DANTE was achieved and is demonstrated by the plot of timestamp differences shown on the left in Figure 4(d)11. The time resolution is similar to that shown earlier in Figure 4(d)10.

Tracking of the ions within PRISMA was not carried out in the on-line analysis, however the performance of PRISMA was monitored with various on-line histograms. Figure 4(d)12 shows the distribution of ions in the PRISMA entrance detector (MCP) without being calibrated.

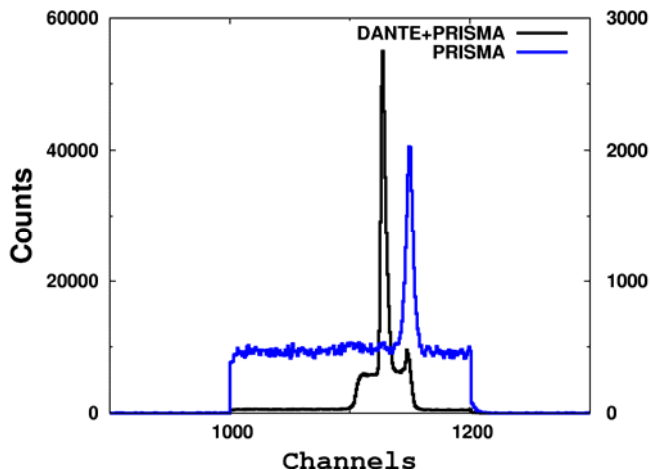


**Figure 4(d)12** Distribution (x and y position) of reaction products in the MCP detector at the PRISMA entrance, before calibration. The four tags on the cross arms, and the two vertical screws, are clearly visible but are skewed. The spectrum is taken from the Week-46 experiment.



**Figure 4(d)13** Distribution (x and y position) of reaction products in the MCP detector at the PRISMA entrance, after calibration. The tags and the screws are now visible in their correct positions [cf. Figure 4(d)12]. This spectrum is taken from the Week-49 experiment.

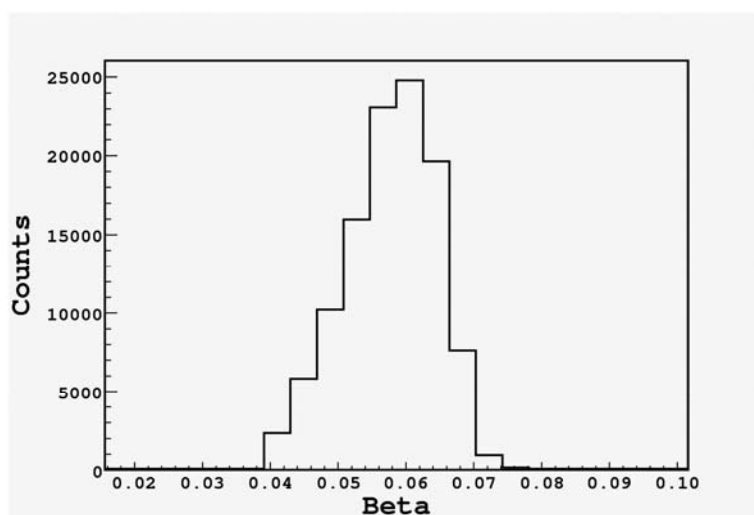
The second in-beam test with the PRISMA spectrometer was carried out in December 2009 (Week 49). The reaction and experimental set-up was used as for the Week-46 experiment. The purpose of the second experiment was the optimization of the on-line PRISMA analysis, and to collect more data to investigate the performance of the AGATA-PRISMA coupling. The time difference spectra for AGATA-DANTE and AGATA-PRISMA are shown in Figure 4(d)14.



**Figure 4(d)14** The timestamp difference between AGATA and DANTE or PRISMA. The black line (and left-hand vertical scale) shows coincidences between AGATA and DANTE or PRISMA. The blue line (and right-hand vertical scale) shows coincidences between AGATA and PRISMA only. The resolution is around 50ns as for the previous experiments.

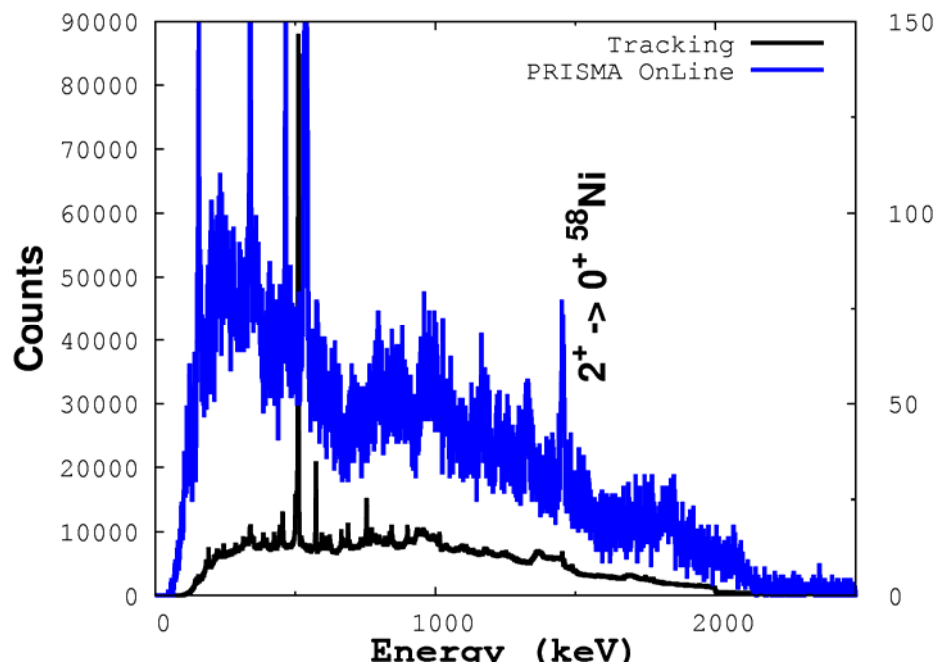
One of the major improvements in the Week-49 experiment was that it was possible to carry out the full “PRISMA analysis” online. It was possible to track the ions entering PRISMA by demanding signals in the entrance detector (MCP) and in the MWPC, selecting the time-of-flight, and to get good agreement between the reconstructed trajectory and the ionization-chamber signals. The on-line calibrated PRISMA-entrance MCP is shown in figure 4(d)13, which can be compared with the figure 4(d)12 from the Week-46 experiment.

The velocity vector of the recoiling reaction products was determined on-line [figure 4(d)15] and passed on via NARVAL to the tracking algorithms where the Doppler correction was performed [figure 4(d)16].



**Figure 4(d)15** On line distribution of the velocity vector of the “good” events entering the PRISMA spectrometer. The centroid corresponds to velocity of  $\beta=0.056c$ .

This report has been prepared very shortly (~2 weeks) after the completion of the Week-49 experiment. The data are still in the preliminary stages of offline analysis. Work is presently ongoing in order to optimize the methods and to understand the procedures necessary.



**Figure 4(d)16** Preliminary spectra taken from the Week-49 test with AGATA coupled to the PRISMA spectrometer. The black line (and the scale on the left-hand side) shows the total gamma-ray spectrum acquired in coincidence with either DANTE or PRISMA, after tracking. The blue line (and the right-hand scale) shows the event-by-event Doppler corrected spectrum using the velocity obtained online from PRISMA.

Attached below is a summary of the in-beam test report that was submitted by the AGATA AMB to the Legnaro PAC in December.

*March 2009 (week 12): the  $^{30}\text{Si}@70\text{MeV}+^{12}\text{C}$  fusion-evaporation reaction was performed. The main goal of the measurement was to obtain information on the position resolution provided by the PSA algorithms. The system comprised ATC1 with a full electronics chain operated in triggerless mode. With the collected dataset it was possible to solve several issues with the positioning of the detector as well with the pulse shape analysis algorithm. Using the information provided by the latter, a peak FWHM of 12.5 keV is obtained for the 1823 keV line of  $^{40}\text{K}$ , which should be compared to 17.7 keV using the segment information only. The obtained values are consistent with a position resolution better than 5 mm FWHM.*

*July 2009 (week 27): the  $^{56}\text{Fe}@220\text{MeV}+^{197}\text{Au}$  Coulomb excitation reaction was performed, namely a reaction similar to the one performed in 2001 with the MARS detector. The main goal of the experiment was to test the trigger processor, performing coincidences with a charged particle detector. The system comprised again ATC1 with its full electronics, an element of the DANTE MCP array, acquired through the electronics of AGATA, and the digital trigger processor. Data were acquired requiring the coincidence between AGATA and DANTE, the information of which was used to perform Doppler correction. The final results are well consistent with the MARS results. A peak FWHM of 4.2 keV is obtained for the 847 keV line of  $^{56}\text{Fe}$ , using the full ATC1 and the full DANTE, which however was suffering from strong alinearities. Limiting the analysis to the most linear area of DANTE and optimizing the crystal axis orientation in the signal basis, a peak FWHM of 3.2 keV is obtained for the same line.*

*October 2009 (week 43): the  $^{32}\text{S}@130\text{MeV}+^{110}\text{Pd}$  fusion-evaporation reaction was performed. The goal of the experiment was twofold: on one hand, it was to test the AGAVA interface in-beam; on the other hand, it was to test the response of the AGATA detectors to high-multiplicity events. The AGATA detectors, in this case two triple clusters, were operated in coincidence with an array of five  $\text{LaBr}_3$  scintillators and with a Si-strip detector. The data analysis is still at a very early stage, however the AGATA- $\text{LaBr}_3$  correlations are clearly visible, proving that the AGAVA interface is properly working.*

*November 2009 (week 46): the  $^{58}\text{Ni}@235\text{MeV}+^{96}\text{Zr}$  multi-nucleon transfer reaction was performed. The goal of the experiment was to test the coupling of AGATA with the PRISMA magnetic spectrometer. Due to many technical problems, the statistics of the collected data is extremely low, suggesting anyway that the coupling, performed through the AGAVA interface, is indeed working.*

*December 2009. As for previous test all of the system worked very successfully. Data analysis is in progress some results may be presented at the meeting.*



Significant UK effort has been devoted to all of these commissioning experiments. The PDRA at UWS (Mengoni) has spent the majority of his time at Legnaro in the present reporting period, contributing significantly to the preparation of the experiments, and the subsequent analysis of the data, as well as their execution. The Project Student at Surrey (Kempley) has also spent extended periods at Legnaro in order to learn the system and to help out with data analysis. PDRA's and Project Students from UWS, Liverpool, Manchester and York have taken part in all of the commissioning experiments to date. The UK is thereby developing a sizeable body of expertise in all aspects of the operation of AGATA.

**(iii) Activities during the next 6 months**

The physics campaign with AGATA at Legnaro will start in early 2010. At the Legnaro PAC meeting in July 2009, three AGATA experiments were approved, which will be scheduled within the first six months of 2010. These experiments were restricted to simple ancillary detectors, without the use of PRISMA. The next PAC meeting is due to be held in early 2010 at which the laboratory will accept proposals using the full range of beams (including beams requiring ALPI) and using PRISMA. It is envisaged that there will be several experiments led by UK physicists submitted to that PAC meeting.

During the next six months, data from the commissioning experiments will be analysed and data from the initial experiments in the physics campaign will be checked. Data analysis codes will be prepared and made available for use to the spokespersons of the physics-campaign experiments

**(iv) Financial Statement: Work Package 4**

	Workpackage 4 Finance Summary (all figures in £k)										Variance						
	Approved (excluding contingency) (1)		Transfers (1a)		Actual spend in previous years (2)		Current year 2009/10		Latest estimate of future requirement (5)		Total						
					for each FY		year		2010/11		2011/12		2012/13		Actual (6-1-1a)		Projected (7-1-1a)
	(1)	(1a)	2008/09	2009/10	(3)	(4)	2010/11	2011/12	2012/13	(6)	(7)	(6)	(7)	(6-1-1a)	(7-1-1a)		
<b>University Staff Effort Costs*</b>																	
Liverpool University Effort (inc. students stipend)	84.03	-17.07	3.78	20.21	10.11	29.05	10.21	13.88	3.72	13.88	66.96	53.08	0.00				
Manchester University Effort	13.64	4.67	0.16	1.07	1.07	6.57	2.24	12.41	0.00	1.24	13.64	-12.41	0.00				
Surrey University Effort (inc. students stipend)	48.87	4.22	4.22	11.47	15.10	13.22	4.85	8.44	4.85	8.44	48.86	-50.43	0.00				
UWS Effort	72.26	-5.58	1.02	6.22	30.80	13.28	3.02	7.24	3.02	66.68	59.44	0.00					
York University Effort (inc. students stipend)	47.16	7.42	4.33	17.65	17.94	8.83	4.33	10.34	4.33	54.58	44.24	0.00					
<b>University Sub-Total*</b>	<b>265.96</b>	<b>-15.23</b>	<b>14.98</b>	<b>72.57</b>	<b>36.15</b>	<b>99.46</b>	<b>47.77</b>	<b>15.94</b>	<b>41.14</b>	<b>250.73</b>	<b>209.59</b>	<b>0.00</b>					
<b>STFC Lab Costs</b>																	
Daresbury	9.24		3.15	4.11	2.86	4.11	1.98	0.00	0.00	6.01	9.24	-3.23	0.00				
Daresbury Overhead	3.50		1.20	1.09	1.55	0.75	0.00	0.00	0.00	3.50	3.50	-1.21	0.00				
<b>STFC Lab Sub-Total</b>	<b>12.74</b>		<b>4.35</b>	<b>5.20</b>	<b>4.36</b>	<b>4.86</b>	<b>1.98</b>	<b>0.00</b>	<b>0.00</b>	<b>9.51</b>	<b>12.74</b>	<b>-4.44</b>	<b>0.00</b>				
<b>Student Fees Liverpool</b>	<b>8.30</b>		<b>1.24</b>	<b>1.24</b>	<b>0.86</b>	<b>1.71</b>	<b>2.36</b>	<b>8.30</b>	<b>0.00</b>	<b>2.09</b>	<b>8.30</b>	<b>-6.20</b>	<b>0.00</b>				
Student Fees Surrey	9.11		1.98	1.98	1.98	2.07	0.61	3.96	9.11	9.11	-5.15	0.00					
Student Fees York	5.42		1.10	0.00	0.00	0.73	1.11	4.81	0.62	1.10	4.81	-4.32	-0.55				
Equipment* Liverpool	11.06			0.00	0.00	11.06				0.00	11.06	-11.06	0.00				
Equipment* Manchester	11.06			0.97	0.85	11.06				0.85	11.06	-10.21	0.00				
Equipment* Surrey	11.06			4.16	4.16	10.09				5.13	11.06	-5.93	0.00				
Equipment* York	17.02			0.00	0.00	17.02				0.00	17.02	-17.02	0.00				
<b>Equipment* Total</b>	<b>61.28</b>		<b>13.99</b>	<b>5.01</b>	<b>49.24</b>	<b>28.29</b>	<b>8.42</b>	<b>2.23</b>	<b>14.43</b>	<b>63.23</b>	<b>42.27</b>	<b>1.95</b>	<b>0.00</b>				
Travel Liverpool	21.26		1.20	3.06	7.20	8.84	3.51	0.81	0.00	3.26	21.96	-17.70	0.00				
Travel Manchester	3.21		0.85	0.77	1.69	2.22	0.00	0.00	0.00	0.77	3.91	-3.14	0.00				
Travel Surrey	11.40		3.25	3.25	5.14	2.38	0.62	4.07	12.25	4.07	12.25	-7.32	0.85				
Travel UWS	15.28		0.36	2.81	6.00	8.91	0.00	3.17	15.27	3.17	15.27	-12.11	0.00				
Travel York	8.34		0.51	0.51	2.17	2.74	2.12	0.80	1.02	8.34	7.32	-0.91	0.00				
Travel STFC	2.05		0.64	0.50	0.97	0.44	0.00	0.00	0.00	1.14	2.05	-0.91	0.00				
<b>Travel Total</b>	<b>62.93</b>		<b>3.56</b>	<b>10.86</b>	<b>21.28</b>	<b>28.29</b>	<b>8.42</b>	<b>2.23</b>	<b>14.43</b>	<b>63.78</b>	<b>48.51</b>	<b>-0.85</b>	<b>0.00</b>				
Other Directly Allocated costs (eg consumables)	0.00																
Liverpool University Estates costs	16.23	-5.76	0.42	2.02	1.61	6.11	0.15	0.05	0.00	2.14	10.48	-8.33	0.00				
Manchester University Estates costs	5.31		0.32	0.30	0.30	2.50	0.88	0.00	0.00	0.62	5.30	-4.69	0.00				
Surrey University Estates costs	2.55		0.29	0.29	0.54	0.63	0.73	0.37	0.58	2.57	1.98	-0.59	0.00				
UWS Estates costs	14.75	-1.10	0.78	1.52	3.73	6.06	2.60	0.49	2.30	13.66	11.35	-2.31	0.00				
York University Estates costs	8.60	3.02	1.04	1.04	5.00	4.48	0.72	0.38	2.08	11.61	9.54	-2.07	0.00				
<b>University Estates costs total</b>	<b>47.46</b>	<b>-3.84</b>	<b>2.55</b>	<b>14.92</b>	<b>5.17</b>	<b>19.79</b>	<b>4.48</b>	<b>1.30</b>	<b>4.30</b>	<b>43.62</b>	<b>35.89</b>	<b>-7.73</b>	<b>0.00</b>				
Liverpool University indirect costs	54.77	-19.43	0.61	6.31	19.63	20.62	30.62	0.51	0.00	7.22	36.33	-38.12	0.00				
Manchester University indirect costs	14.38		0.63	0.61	4.35	6.80	2.27	0.00	0.00	1.67	14.38	-12.71	0.00				
Surrey University indirect costs	5.89		0.67	0.67	1.24	1.44	1.66	0.85	0.00	1.33	5.88	-4.53	0.00				
UWS indirect costs	58.79	-4.68	1.21	5.68	14.33	24.65	9.93	1.90	6.90	52.08	46.18	-5.89	0.00				
York University indirect costs	17.02	-5.99	2.06	2.06	9.90	8.70	1.55	0.80	4.12	23.01	18.89	-4.12	0.00				
<b>University indirect costs</b>	<b>148.79</b>	<b>-18.12</b>	<b>5.21</b>	<b>16.03</b>	<b>43.44</b>	<b>62.21</b>	<b>16.09</b>	<b>3.72</b>	<b>21.24</b>	<b>130.67</b>	<b>-109.43</b>	<b>0.00</b>					
<b>Total (Excluding VAT and WA)</b>	<b>621.97</b>	<b>-37.19</b>	<b>48.97</b>	<b>211.43</b>	<b>70.02</b>	<b>218.52</b>	<b>82.92</b>	<b>25.21</b>	<b>118.99</b>	<b>587.04</b>	<b>465.80</b>	<b>2.26</b>					
Working allowance																	
VAT	17.50%		2.10	8.62	0.75	8.62	0.00	0.00	0.00	2.85	10.72	-7.87	-0.01				
	15.00%																
<b>Total (including VAT &amp; WA)</b>	<b>632.70</b>	<b>-37.19</b>	<b>51.07</b>	<b>220.05</b>	<b>70.77</b>	<b>218.52</b>	<b>82.92</b>	<b>25.21</b>	<b>121.84</b>	<b>597.76</b>	<b>473.67</b>	<b>2.25</b>					

Contingency (held by STFC)

\* Excluding workshop Allowance and VAT

\* The University staff effort recorded in this table should be the 80% amount STFC pays, including academic time

Use of columns:

- (1) = The amount approved by STFC
- (1a) = This column should be used to show any movements between headings, for example when Working Allowance is used, the amount should appear as a debit in the WA row and then credited to the relevant row
- (2) = The actual spend in previous financial years, by year
- (3) = The actual spend in the current financial year up to the most recent quarter
- (4) = The total projected spend for the current financial year, including any expenditure so far (ie actual spend this year plus predictions of remaining spend this year)
- (5) = Projected spend for the remaining years
- (6) = The actual spend so far
- (7) = Projected spend over the whole duration of the project (ie actual spend so far plus predictions of remaining spend to project completion)

The variance columns show the difference between the actual and projected amounts and the approved amount.

**(v) Resource Usage: Work Package 4**

WP4								
NAME	INSTITUTE	% FTE 2008/09	% FTE 2009/10	% FTE 2010/11	% FTE 2011/12	% FTE 2012/13	Total Effort	Effort Remaining
A Boston	Liverpool	0.010	0.020	0.020	0.015	0.005	0.070	0.040
Liverpool PDRA	Liverpool	0.000	0.400	0.600	0.000	0.000	1.000	0.600
Liverpool Student	Liverpool	0.251	0.575	0.775	0.699	0.250	2.550	1.724
Manchester PDRA	Manchester	0.000	0.138	0.200	0.062	0.000	0.400	0.262
J Smith	UWS	0.033	0.099	0.099	0.099	0.066	0.396	0.264
UWS PDRA	UWS	0.000	0.442	0.800	0.258	0.000	1.500	1.058
Z Podolyak	Surrey	0.015	0.030	0.040	0.050	0.025	0.160	0.115
P Regan	Surrey	0.011	0.022	0.022	0.022	0.011	0.088	0.055
Walker	Surrey	0.011	0.022	0.022	0.022	0.011	0.088	0.055
Surrey Student	Surrey	0.251	0.600	0.800	0.624	0.175	2.450	1.599
M Bentley	York	0.027	0.054	0.054	0.054	0.027	0.216	0.135
Joshi	York	0.050	0.301	0.249	0.000	0.000	0.600	0.249
York Student	York	0.300	0.250	0.370	0.425	0.200	1.545	0.995
Marc Labiche	Daresbury	0.064	0.104	0.042	0.000	0.000	0.210	0.042

**(vi) Milestones: Work Package 4**

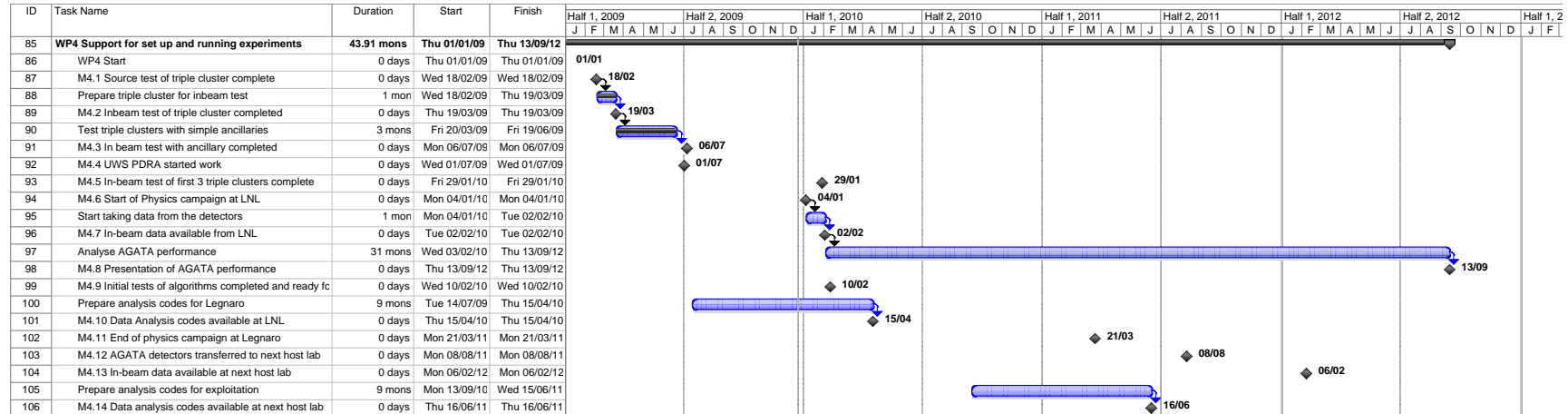
<u>Milestone No.</u>	<u>Work Package</u>	<u>Milestone</u>	<u>Target Date</u>	<u>Status</u>
M4.3	WP4	In beam test with ancillary completed	6 July 09	Complete
M4.4	WP4	UWS PDRA started work	1 July 09	Complete

<u>Milestone no.</u>	<u>Work Package</u>	<u>Milestone</u>	<u>Target Date</u>	<u>Status</u>
M4.5	WP4	In-beam test of first 3 triple clusters	29 Jan 10	
M4.6	WP4	Start of physics campaign at LNL	4 Jan 10	
M4.7	WP4	In-Beam data available from LNL	2 Feb 10	
M4.9	WP4	Initial tests of the algorithms completed and ready for implementation	10 Feb 10	
M4.10	WP4	Data analysis codes available at LNL	15 Apr 10	

<u>Mile-stone No.</u>	<u>Work Package</u>	<u>Milestone</u>	<u>As at June 09</u>	<u>As at Sept 09</u>	<u>Delay due to</u>		<u>Affects Critical Path?</u>	<u>See Note</u>
					<u>UK?</u>	<u>Others?</u>		
M4.1	WP4	Source test of a triple cluster	18 Feb 09	18 Feb 09				Complete
M4.2	WP4	In beam test of a triple cluster	19 Mar 09	19 Mar 09				Complete
M4.3	WP4	In-beam test of a triple cluster with ancillary detector	6 July 09	6 July 09				Complete
M4.4	WP4	UWS PDRA started work	1 July 09	1 July 09				Complete
M4.5	WP4	In-beam test of first 3 triple clusters	31 Dec 09	29 Jan 10				
M4.6	WP4	Commencement of Physics campaign at	4 Jan 10	4 Jan 10				

		LNL						
M4.7	WP4	In-beam data available from LNL	2 Feb 10	2 Feb 10				
M4.8	WP4	Preliminary presentation of AGATA performance	13 Sep 12					
M4.9	WP4	Initial tests of algorithms completed and ready for implementation	10 Feb 10	10 Feb 10				
M4.10	WP4	Data analysis codes available at LNL	15 Apr 10	15 Apr 10				
M4.11	WP4	End of Physics campaign at LNL	21 Mar 11	21 Mar 11				
M4.12	WP4	AGATA detectors transferred to next host lab	8 Aug 11	8 Aug 11				
M4.13	WP4	In beam data available from next host lab	7 Sep 11	7 Sep 11				
M4.14	WP4	Data analysis codes available at next host lab	16 June 11	16 June 11				

(vii) Gantt Chart: Work Package 4



(viii) Earned Value Analysis: Work Package 4

ID	Task Name	Planned Value - PV (BCWS)	Earned Value - EV (BCWP)	AC (ACWP)	SPI	CPI	SV	CV	EAC	BAC	VAC
1	<b>WP4 Support for set up and running experiments</b>	<b>£36,214.31</b>	<b>£23,092.19</b>	<b>£23,092.19</b>	<b>0.64</b>	<b>1</b>	<b>-£13,122.13</b>	<b>£0.00</b>	<b>£260,899.05</b>	<b>£260,899.05</b>	<b>£0.00</b>
2	WP4 Start	£0.00	£0.00	£0.00	0	0	£0.00	£0.00	£0.00	£0.00	£0.00
3	M4.1 Source test of triple cluster complete	£0.00	£0.00	£0.00	0	0	£0.00	£0.00	£0.00	£0.00	£0.00
4	Prepare triple cluster for inbeam test	£6,112.97	£6,112.97	£6,112.97	1	1	£0.00	£0.00	£6,112.97	£6,112.97	£0.00
5	M4.2 Inbeam test of triple cluster completed	£0.00	£0.00	£0.00	0	0	£0.00	£0.00	£0.00	£0.00	£0.00
6	Test triple clusters with simple ancillaries	£2,222.90	£2,222.90	£2,222.90	1	1	£0.00	£0.00	£2,222.90	£2,222.90	£0.00
7	Test triple clusters with simple ancillaries	£14,756.31	£14,756.31	£14,756.31	1	1	£0.00	£0.00	£14,756.31	£14,756.31	£0.00
8	M4.3 In beam test with ancillary completed	£0.00	£0.00	£0.00	0	0	£0.00	£0.00	£0.00	£0.00	£0.00
9	M4.4 UWS PDRA started work	£0.00	£0.00	£0.00	0	0	£0.00	£0.00	£0.00	£0.00	£0.00
10	M4.5 In-beam test of first 3 triple clusters complete	£0.00	£0.00	£0.00	0	0	£0.00	£0.00	£0.00	£0.00	£0.00
11	M4.6 Start of Physics campaign at LNL	£0.00	£0.00	£0.00	0	0	£0.00	£0.00	£0.00	£0.00	£0.00
12	Start taking data from the detectors	£0.00	£0.00	£0.00	0	0	£0.00	£0.00	£5,951.05	£5,951.05	£0.00
13	M4.7 In-beam data available from LNL	£0.00	£0.00	£0.00	0	0	£0.00	£0.00	£0.00	£0.00	£0.00
14	Analyse AGATA performance	£0.00	£0.00	£0.00	0	0	£0.00	£0.00	£5,680.55	£5,680.55	£0.00
15	Analyse AGATA performance	£0.00	£0.00	£0.00	0	0	£0.00	£0.00	£67,591.48	£67,591.48	£0.00
16	Analyse AGATA performance	£0.00	£0.00	£0.00	0	0	£0.00	£0.00	£47,685.13	£47,685.13	£0.00
17	Analyse AGATA performance	£0.00	£0.00	£0.00	0	0	£0.00	£0.00	£16,047.01	£16,047.01	£0.00
18	M4.8 Presentation of AGATA performance	£0.00	£0.00	£0.00	0	0	£0.00	£0.00	£0.00	£0.00	£0.00
19	M4.9 Initial tests of algorithms completed and ready for implementation	£0.00	£0.00	£0.00	0	0	£0.00	£0.00	£0.00	£0.00	£0.00
20	Prepare analysis codes for Legnaro	£13,122.13	£0.00	£0.00	0	0	-£13,122.13	£0.00	£42,225.63	£42,225.63	£0.00
21	Prepare analysis codes for Legnaro	£0.00	£0.00	£0.00	0	0	£0.00	£0.00	£3,518.61	£3,518.61	£0.00
22	M4.10 Data Analysis codes available at LNL	£0.00	£0.00	£0.00	0	0	£0.00	£0.00	£0.00	£0.00	£0.00
23	M4.11 End of physics campaign at Legnaro	£0.00	£0.00	£0.00	0	0	£0.00	£0.00	£0.00	£0.00	£0.00
24	M4.12 AGATA detectors transferred to next host lab	£0.00	£0.00	£0.00	0	0	£0.00	£0.00	£0.00	£0.00	£0.00
25	M4.13 In-beam data available at next host lab	£0.00	£0.00	£0.00	0	0	£0.00	£0.00	£0.00	£0.00	£0.00
26	Prepare analysis codes for exploitation	£0.00	£0.00	£0.00	0	0	£0.00	£0.00	£20,207.56	£20,207.56	£0.00
27	Prepare analysis codes for exploitation	£0.00	£0.00	£0.00	0	0	£0.00	£0.00	£28,899.84	£28,899.84	£0.00
28	M4.14 Data analysis codes available at next host lab	£0.00	£0.00	£0.00	0	0	£0.00	£0.00	£0.00	£0.00	£0.00

4(e)            Work Package 5            **Electronics and Graphical User Interface (GUI) software**

**Leader:**            Ian Lazarus (STFC Daresbury Laboratory)

**Institutes:**        STFC Daresbury Laboratory and Liverpool

**(i)        Brief summary of WP tasks**

- Support the AGATA demonstrator in LNL- this includes support of digitiser (hardware, mechanics, firmware and slow control), pre-processing (team management), and system slow control (advice and participation in team).
- Manufacture additional digitisers to current design for use with detectors delivered while new electronics is defined, designed and built.
- Design and development of new upgraded digitiser.
- Involvement in AGATA working groups and teams, participation in discussion about AGATA electronics and DAQ.

**(ii)        Activities during the past 6 months (July 2009 to Dec 2009)**

The main work has been towards completing the installation and system test of the AGATA demonstrator at Legnaro which is expected to be complete in early 2010 (3 triple clusters by the end of 2009). The timescale is dictated by the delivery of detectors which is presently running behind the electronics (all electronics required for detector deliveries to the end of 2009 is already manufactured, tested and delivered). This has been the top priority task. Activity has included: management of pre-processing team, shipping digitisers to LNL, participation in and advice to slow control team who have decided to adopt the slow control philosophy proposed in June by Pucknell. In parallel with work on the demonstrator the other task has been preparing discussion options for the AGATA EDAQ system upgrades ready for presentation to the other AGATA partners and planning the manufacture of 7 digitisers to the current design (4 funded from UK, 3 from Italy). The negotiations with partners over funding took place over the summer and were concluded in September 2009. The review of the design files prior to obtaining quotes has taken place and the tender exercise carried out for manufacture of 7 more digitisers.

A report on possible use of commercial of the shelf (COTS) electronics is being prepared as background to the discussions planned for early 2010 with the rest of the collaboration about options and specifications for the new electronics. This is significantly later than scheduled but the timing of the discussions is determined by the whole AGATA collaboration. During the discussions we will try to scale the amount of any re-design work, or the complexity of the COTS option, according to available time and manpower so as to try to recover as much of the lost time as possible.

Timescale may define that all the detectors operate at GSI with the current design. That will mean that the construction tasks in this WP, leading to M5.6, M5.7 and M8.12, will be revised to replace the manufacture of upgraded digitisers by manufacture of further digitisers to the current design. However, the reasons for an upgrade remain valid and for the GANIL phase the upgraded electronics will be needed, so the design work leading to M5.4 and M5.5 will be undertaken anyway although the construction phase would become part of the follow-on funding application for the GANIL phase of AGATA if the construction money in this grant is used on digitisers to the current design.

An additional risk has been added to the register to describe the impact to the project of delays caused by slow decisions and agreement from our partners in the collaboration, which significantly delay progress in UK.

**(iii) Activities during the next 6 months (Jan 2010 to June 2010)**

	<b>Task</b>	<b>People Involved</b>	<b>End Date</b>
1	System commissioning in Legnaro (building up system from 3 to 6 triple clusters and associated EDAQ- 4 <sup>th</sup> triple cluster due early 2010 and others to follow)	Pucknell, Coleman-Smith, Lazarus, Wells and Thornhill	Mid 2010
2	Conclude discussions on AGATA EDAQ system upgrades with AGATA partners.	Mainly Lazarus, Coleman-Smith and Pucknell	July 2010
3	Production of 7 digitisers to current design for delivery by the end of 2010	Coleman-Smith, Lazarus, Wells and Thornhill	Delivery-March 2011
4	Participate in AGATA slow control team (meetings and writing software)	Pucknell	Ongoing
5	Manage pre-processing team	Lazarus	Ongoing
6	Support the AGATA system in Legnaro as required after commissioning	All	Ongoing



(iv) Financial Statement: Work Package 5

Workpackage 5 Finance Summary (all figures in £k)

	Approved (excluding contingency) (1)	Transfers (1a)	Actual spend in previous years (2)		Current year 2009/10		Latest estimate of future requirement (5)			Total		Variance	
			for each FY		Actual Spend to end Sept 09 (3)	Projected spend this year (4)	2010/11	2011/12	2012/13	Actual spend (2+3) (6)	Projected spend (2+4+5) (7)	Actual (6-1-1a)	Projected (7-1-1a)
			2008/09	2009/10									
<b>University Staff Effort Costs*</b>													
Liverpool University Effort													
Manchester University Effort													
Surrey University Effort													
LWS Effort													
York University Effort													
<b>University Sub-Total</b>													
<b>STFC Lab Costs</b>													
Daresbury	212.61		19.97	65.44	30.78	65.44	76.61	40.98	0.61	50.73	212.61	-161.88	0.00
Daresbury Overheads	92.70		7.73	28.88	11.86	28.88	34.11	17.89	4.09	19.59	92.70	-73.11	0.00
<b>STFC Lab Sub-Total</b>	<b>305.31</b>		<b>27.70</b>	<b>94.32</b>	<b>42.62</b>	<b>94.32</b>	<b>110.72</b>	<b>58.87</b>	<b>13.70</b>	<b>70.31</b>	<b>305.31</b>	<b>-234.99</b>	<b>0.00</b>
Equipment <sup>1</sup>													
Travel STFC	31.94		3.67	8.23	0.78	8.23	10.37	7.58	2.08	4.45	31.94	-27.49	0.00
Travel Liverpool	4.29			1.27	0.00	1.27	1.64	1.01	0.37	4.28	4.29	-4.29	0.00
<b>Travel Total</b>	<b>36.23</b>		<b>3.67</b>	<b>9.50</b>	<b>0.78</b>	<b>9.50</b>	<b>12.01</b>	<b>8.59</b>	<b>2.46</b>	<b>4.45</b>	<b>36.23</b>	<b>-31.78</b>	<b>0.00</b>
Other Directly Allocated costs STFC	36.13		5.24	8.61	5.24	8.61	9.07	9.27	3.95	10.48	36.13	-25.65	0.00
Other Directly Allocated costs Liverpool	5.66			1.62	0.00	1.62	1.84	1.46	0.75	5.66	5.66	-5.66	0.00
<b>Other Directly Allocated costs (eg consumables) Total</b>	<b>41.79</b>		<b>5.24</b>	<b>10.23</b>	<b>5.24</b>	<b>10.23</b>	<b>10.91</b>	<b>10.72</b>	<b>4.69</b>	<b>10.48</b>	<b>41.79</b>	<b>-31.31</b>	<b>0.00</b>
Liverpool University Estates costs													
Manchester University Estates costs													
Surrey University Estates costs													
LWS Estates costs													
<b>University Estates costs total</b>													
Liverpool University Indirect costs													
Manchester University Indirect costs													
Surrey University Indirect costs													
LWS Indirect costs													
<b>University Indirect costs</b>													
<b>Total (Excluding VAT and WA)</b>	<b>383.33</b>		<b>36.61</b>	<b>114.05</b>	<b>48.64</b>	<b>114.05</b>	<b>133.64</b>	<b>78.18</b>	<b>20.85</b>	<b>85.25</b>	<b>383.33</b>	<b>-298.08</b>	<b>0.00</b>
Working allowance	0.00		0.00	0.00	0.00	0.00	0.00	0.00	0.00	0.00	0.00	0.00	0.00
VAT	17.50%												
	15.00%												
<b>Total (including VAT &amp; WA)</b>	<b>383.33</b>		<b>36.61</b>	<b>114.05</b>	<b>48.64</b>	<b>114.05</b>	<b>133.64</b>	<b>78.18</b>	<b>20.85</b>	<b>85.25</b>	<b>383.33</b>	<b>-298.08</b>	<b>0.00</b>
<b>Rolling Grant Effort</b>													
Liverpool Rolling Grant Effort	22.62			6.55	3.28	6.55	7.60	6.16	2.31	3.28	22.62	-19.34	0.00
Liverpool Rolling Grant Estates	5.29			1.50	0.75	1.50	1.80	1.46	0.52	0.75	5.29	-4.54	0.00
Liverpool Rolling Grant Indirect	17.83			5.14	2.57	5.14	6.09	4.86	1.75	2.57	17.83	-15.26	0.00
<b>Total Rolling Grant Cost</b>	<b>45.74</b>		<b>0.00</b>	<b>13.19</b>	<b>6.60</b>	<b>13.19</b>	<b>15.49</b>	<b>12.48</b>	<b>4.57</b>	<b>6.60</b>	<b>45.73</b>	<b>-39.14</b>	<b>0.00</b>
<b>Total (including VAT &amp; WA &amp; Rolling Grant)</b>	<b>429.07</b>		<b>36.61</b>	<b>127.24</b>	<b>55.23</b>	<b>127.24</b>	<b>149.13</b>	<b>90.66</b>	<b>25.42</b>	<b>91.84</b>	<b>429.06</b>	<b>-337.22</b>	<b>0.00</b>

Contingency (held by STFC)

<sup>1</sup>Excluding workshop Allowance and VAT

<sup>2</sup>The University staff effort recorded in this table should be the 80% amount STFC pays, including academic time

Use of columns:

(1) = The amount approved by STFC

(1a) = This column should be used to show any variations between headings, for example when Working Allowance is used, the amount should appear as a debit in the VA row and then credited to the relevant row

(2) = The actual spend in previous financial years, by year

(3) = The actual spend in the current financial year up to the most recent quarter

(4) = The total projected spend for the current financial year, including any expenditure so far (ie actual spend this year plus predictions of remaining spend this year)

(5) = Projected spend for the remaining years

(6) = The actual spend so far

(7) = Projected spend over the whole duration of the project (ie actual spend so far plus predictions of remaining spend to project completion)

The variance columns show the difference between the actual and projected amounts and the approved amount.

(v) Resource Usage: Work Package 5

WP5								
NAME	INSTITUTE	% FTE 2008/09	% FTE 2009/10	% FTE 2010/11	% FTE 2011/12	% FTE 2012/13	Total Effort	Effort Remaining
P Coleman-Smith	Daresbury	0.058	0.333	0.383	0.183	0.043	1.000	0.609
I Lazarus	Daresbury	0.058	0.298	0.358	0.183	0.043	0.940	0.584
VHDL Engineer	Daresbury	0.058	0.304	0.374	0.180	0.034	0.950	0.588
V Pucknell	Daresbury	0.128	0.214	0.122	0.026	0.000	0.490	0.148
S Letts	Daresbury	0.000	0.000	0.093	0.125	0.042	0.260	0.260
J Thornhill	Liverpool	0.025	0.065	0.065	0.050	0.025	0.230	0.140
D Wells	Liverpool	0.025	0.075	0.100	0.075	0.025	0.300	0.200

(vi) Milestones: Work Package 5

Milestone No.	Work Package	Milestone	Target Date	Status
M5.2	WP5	Funding agreed for first batch of digitisers	30 July 09	Complete

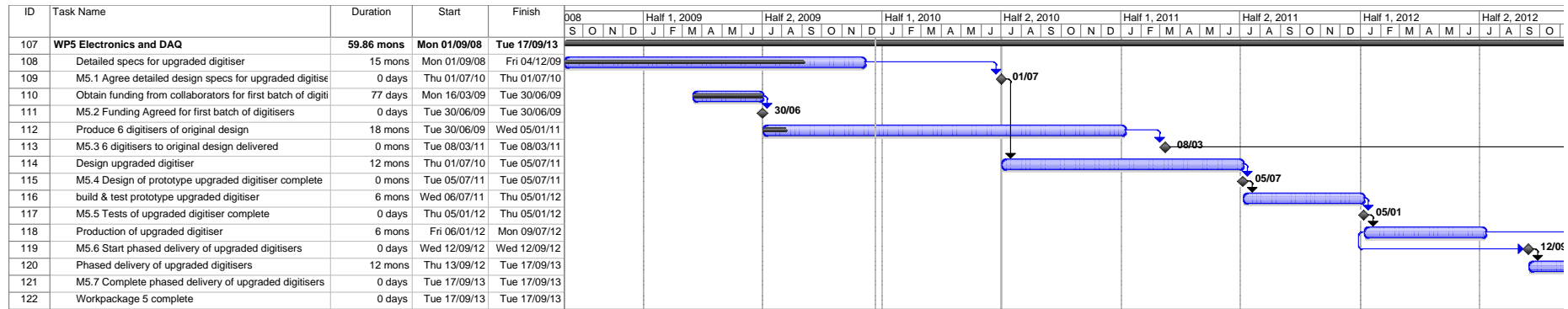
Milestone no.	Work Package	Milestone	Target Date	Status
M5.1	WP5	Agree detailed design specs for upgraded digitisers	July 2010	

Milestone No.	Work Package	Milestone	As at June 09	As at Sept 09	Delay due to		Affects Critical Path?	See Note
					UK?	Others?		
M5.1	WP5	Agree detailed design specs for upgraded digitisers	4 Dec 09	July 2010		Y	Y	Delayed until mid 2010

M5.2	WP5	Funding agreed for first batch of digitisers	30 Jun 09	15 Sept 09		Y		Funding changed by AMB from Italy to Germany and then back to Italy (Germany had to spend money before digitiser delivery) - Complete
M5.3	WP5	Deliver 7 digitisers to original design	5 Jan 10	8 Mar 11		Y		Delay due to delay in funding from collaboration (M5.2)
M5.4	WP5	Design of prototype upgraded digitiser complete	9 Dec 10	July 11		Y		Delay due to delay in agreeing design spec M5.1
M5.5	WP5	Tests of prototype upgraded digitiser complete	13 June 11	Jan 12		Y		Delay due to delay in agreeing design spec M5.1
M5.6	WP5	Start phased delivery of upgraded digitisers	12 Sep 11	12 Sept 11		Y		Delay due to delay in agreeing design spec M5.1. No longer clear that new design can be built during the project lifetime- this milestone may be revised to a second batch of digitisers to the current design produced to instrument all detectors available in GSI phase with a separate later bid to build the new design for the GANIL phase of AGATA . In this case the date will remain Sept 2011 as scheduled.

M5.7	WP5	Complete phased delivery of upgraded digitisers	17 Sep 12	17 Sept 12		Y		Delay due to delay in agreeing design spec  M5.1
------	-----	---	-----------	------------	--	---	--	--

(vii) Gantt Chart: Work Package 5



(viii) Earned Value Analysis: Work Package 5

ID	Task Name	Planned Value - PV (BCWS)	Earned Value - EV (BCWP)	AC (ACWP)	SPI	CPI	SV	CV	EAC	BAC	VAC
1	<b>WP5 Electronics and DAQ</b>	<b>£52,080.28</b>	<b>£43,447.64</b>	<b>£43,447.30</b>	<b>0.83</b>	<b>1</b>	<b>-£8,632.64</b>	<b>£0.35</b>	<b>£235,599.52</b>	<b>£235,601.39</b>	<b>£1.88</b>
2	Detailed specs for upgraded digitiser	£19,360.42	£19,360.42	£19,360.42	1	1	£0.00	£0.00	£19,360.42	£19,360.42	£0.00
3	Detailed specs for upgraded digitiser	£21,752.43	£19,226.29	£19,226.29	0.88	1	-£2,526.14	£0.00	£29,313.22	£29,313.22	£0.00
4	M5.1 Agree detailed design specs for upgraded digitisers	£0.00	£0.00	£0.00	0	0	£0.00	£0.00	£0.00	£0.00	£0.00
5	Obtain funding from collaborators for first batch of digitisers	£0.00	£0.00	£0.00	0	0	£0.00	£0.00	£0.00	£0.00	£0.00
6	M5.2 Funding Agreed for first batch of digitisers	£0.00	£0.00	£0.00	0	0	£0.00	£0.00	£0.00	£0.00	£0.00
7	Produce 6 digitisers of original design	£10,967.43	£4,860.93	£4,860.59	0.44	1	-£6,106.50	£0.35	£29,661.00	£29,663.11	£2.11
8	Produce 6 digitisers of original design	£0.00	£0.00	£0.00	0	0	£0.00	£0.00	£36,771.22	£36,771.22	£0.00
9	M5.3 6 Digitisers to original design delivered	£0.00	£0.00	£0.00	0	0	£0.00	£0.00	£0.00	£0.00	£0.00
10	Design upgraded digitiser	£0.00	£0.00	£0.00	0	0	£0.00	£0.00	£30,718.22	£30,718.22	£0.00
11	Design upgraded digitiser	£0.00	£0.00	£0.00	0	0	£0.00	£0.00	£12,984.08	£12,984.08	£0.00
12	M5.4 Design of prototype upgraded digitiser complete	£0.00	£0.00	£0.00	0	0	£0.00	£0.00	£0.00	£0.00	£0.00
13	build & test prototype upgraded digitiser	£0.00	£0.00	£0.00	0	0	£0.00	£0.00	£25,204.40	£25,204.40	£0.00
14	M5.5 Tests of upgraded digitiser complete	£0.00	£0.00	£0.00	0	0	£0.00	£0.00	£0.00	£0.00	£0.00
15	Production of upgraded digitiser	£0.00	£0.00	£0.00	0	0	£0.00	£0.00	£18,162.26	£18,162.26	£0.00
16	M5.6 Start phased delivery of upgraded digitisers	£0.00	£0.00	£0.00	0	0	£0.00	£0.00	£0.00	£0.00	£0.00
17	Phased delivery of upgraded digitisers	£0.00	£0.00	£0.00	0	0	£0.00	£0.00	£21,504.52	£21,504.52	£0.00
18	Phased delivery of upgraded digitisers	£0.00	£0.00	£0.00	0	0	£0.00	£0.00	£11,919.94	£11,919.94	£0.00
19	M5.7 Complete phased delivery of upgraded digitisers	£0.00	£0.00	£0.00	0	0	£0.00	£0.00	£0.00	£0.00	£0.00
20	Workpackage 5 complete	£0.00	£0.00	£0.00	0	0	£0.00	£0.00	£0.00	£0.00	£0.00

4(f) Work Package 6 **Mechanical design**

**Leader:** Mr J Strachan – STFC Daresbury Laboratory

**Institutes:** STFC Daresbury Laboratory and Liverpool

**(i) Brief summary of WP tasks**

- The UK has provided the mechanical design for the Legnaro installation and will oversee the mechanical installation and help trouble shoot any problems
- The UK will provide the mechanical design for installation of AGATA at GSI and GANIL.
- The tasks for both set-ups will include conceptual design, detailed CAD design, FEA analysis, procurement co-ordination, trial assembly in the UK (Daresbury), commissioning, and project co-ordination.

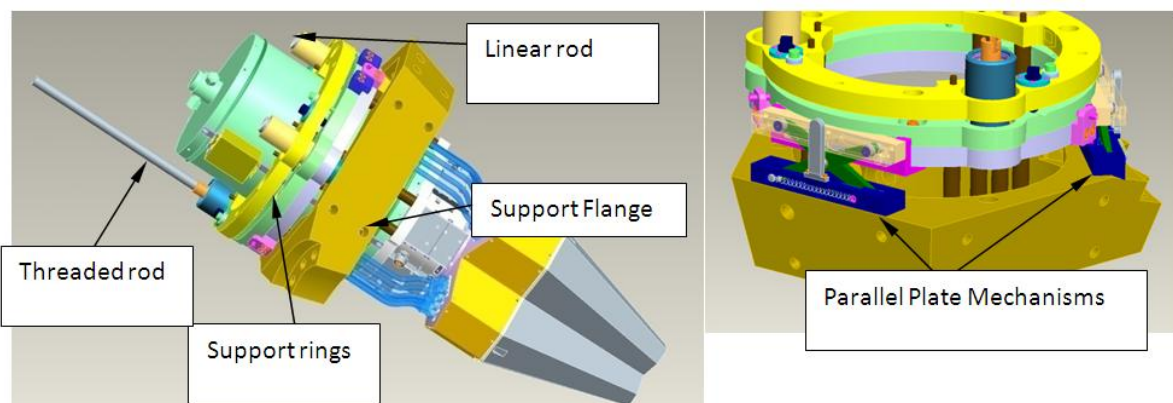
**(ii) Activities during the past 6 months**

In the period prior to July 2009 there were two main issues mechanically.

- It was discovered that there was a problem with a minor deflection of the detector during loading and unloading of the detector. It was proposed that further work should be done to establish the reasons for the deflection and resolve it.
- The location of the next host laboratory was in doubt and so it was not possible to begin the design work to determine what detector array structure would be required.

*1. Detector Deflection progress*

Further FEA was carried out on the support rings to analyse their contribution to the deflection, the results obtained indicated that this was minimal. Hence the problem still lies with the threaded rod. All forces and moments generated by the detector act on the threaded rod, and a small level of bending in the rod generates a large movement at the detector tip. Currently we see a 1mm movement of the detector tip which correlates to 0.1mm movement of the threaded rod. The aim is to reduce the movement of the detector tip to 0.1mm; therefore, the rod must move no more than 10 microns.



**Figure 4(f)1** Detector Deflection

To overcome this, parallel plate mechanisms as shown in Figure 4(f)1 are proposed. These will be located between the support rings and the support flange. The principle is that the support rings will engage the parallel plate mechanisms as they are lowered toward the support flange. The parallel

plate mechanism then forces the support rings parallel to the support flange thus correctly locating the detector. Because the parallel motion mechanisms have a larger engagement than the threaded rod the precision requirements are lower (in the order of 50 micron). A prototype has been manufactured and testing will take place at Daresbury in January.

## 2. Design of support structure for the next host lab.

Since the last OC meeting the location of the next host lab has been established as GSI in Germany. Simulation work has been undertaken on the optimal geometry that can be achieved using triples. The high recoil velocities at GSI mean that the design philosophy is completely different to that for Legnaro. The gamma efficiency, because of the Lorentz and Doppler effects is concentrated in forward angles. Consequently the AGATA design has to follow the design concepts of the RISING spectrometer, also performed by the UK. AGATA will have to be designed to exist in the S4 area of GSI and the design has to take into account the target chamber, the downstream recoil detectors (LYCCA) and will aim to reuse as much of the existing mechanics (rails etc.) that were installed for RISING. The AGATA simulation team proposed two geometries S2 and S3 as shown in Figure 4(f)2. These were built into the CAD system to check they were mechanically possible. S2 is symmetrical around the beam pipe but is not efficient at shallow angles, S3 is more efficient at shallow angles but is non-symmetrical.

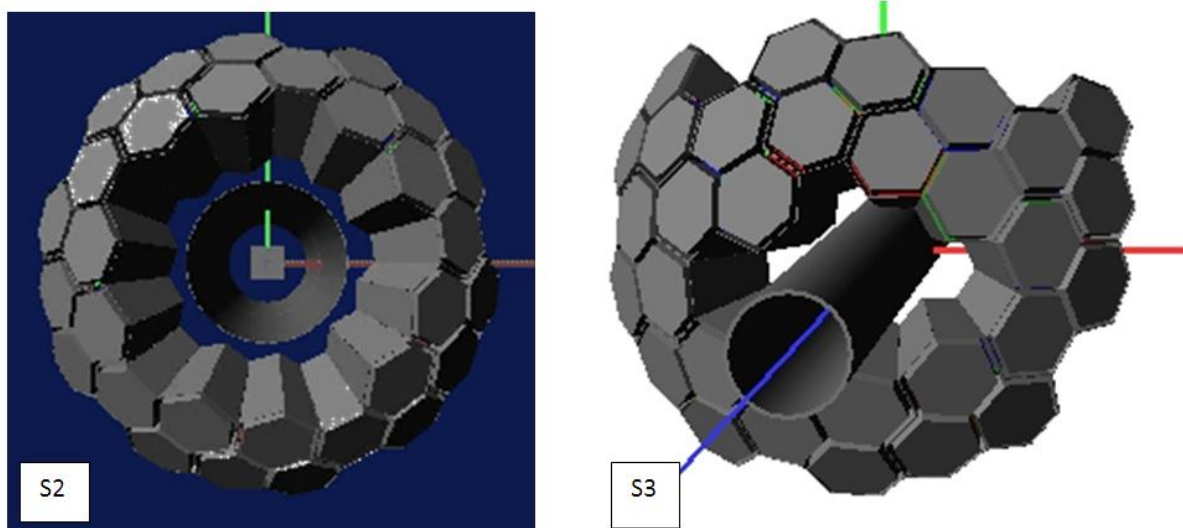
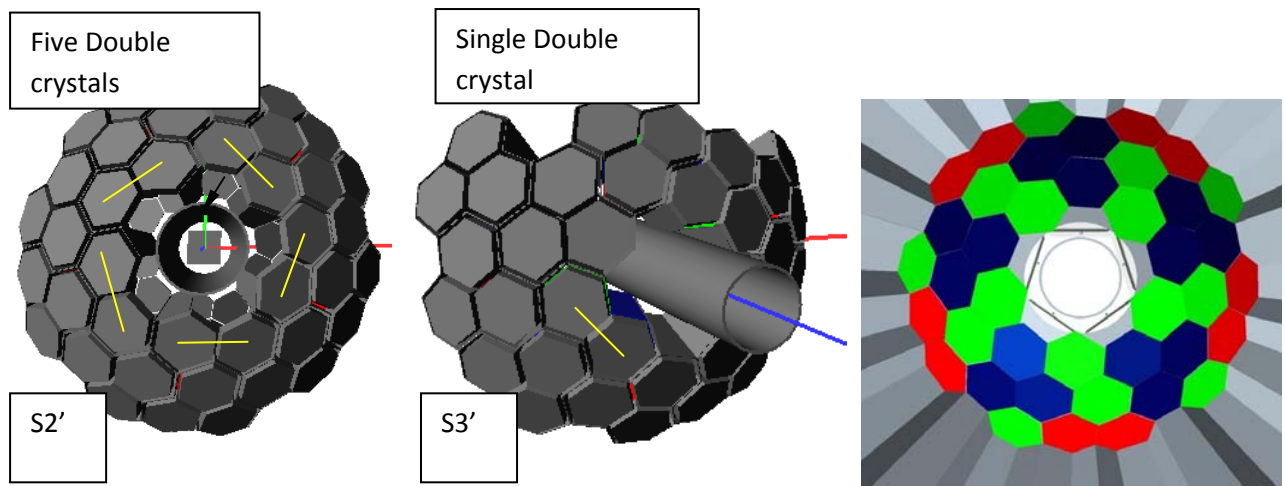


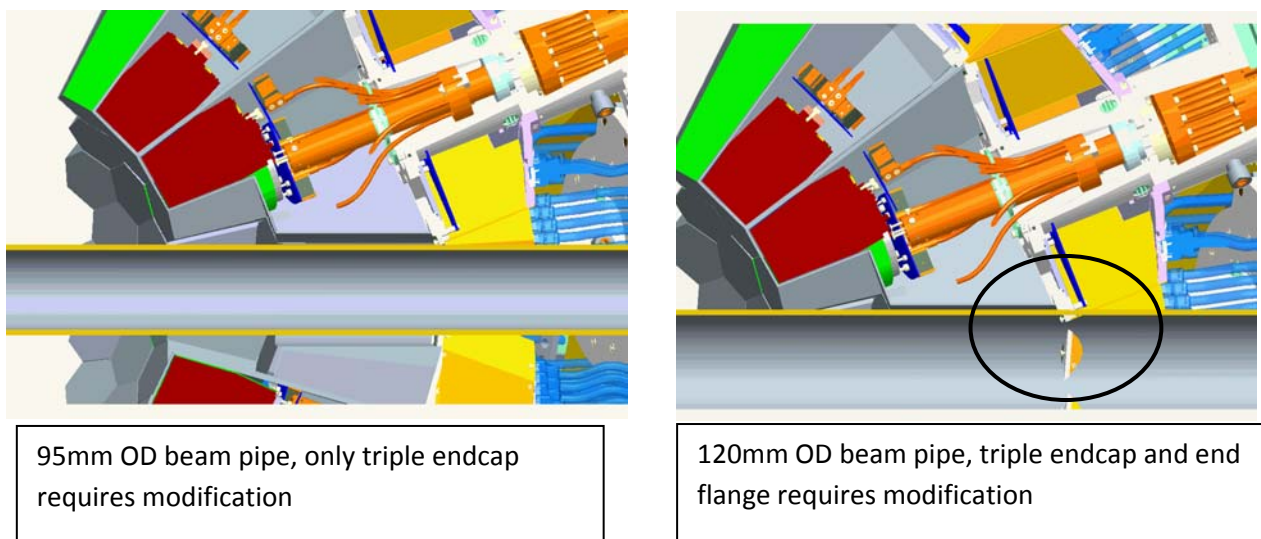
Figure 4(f)2 S2 and S3 geometries.

The collaboration then discussed the use of double clusters with two rather than three capsules in one cryostat. Double Cluster Detectors were then created in the CAD system and the S2 and S3 geometries updated to reflect this. S2' requires 5 double clusters, which should be the first detectors installed, and S3' requires 1 double cluster. In terms of simulated physics performance S2' is the more optimal of the arrays.



**Figure 4(f)3** S2' and S3' geometries the third image shows the S2' geometries with the crystal colours.

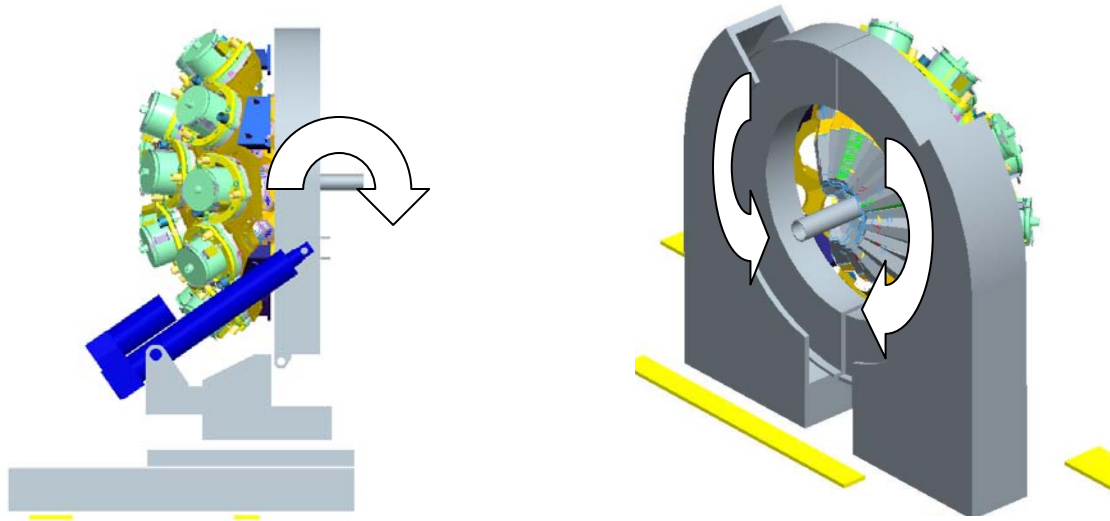
Design work was then undertaken to assess the feasibility of creating Double Cluster Detectors. Two beam pipe diameters 95mm and 120mm were studied. From a mechanical perspective 95mm is much preferred as this requires little modification to the existing triple cluster cryostat, only the endcap must be replaced. A 120mm beam pipe is also possible but requires significant modifications to the cryostat design. Discussions within the collaboration and with the cryostat manufacturer are currently taking place



**Figure 4(f)4** Double cluster Detector design studies.

Design Studies are underway on how the array of detectors would be supported at GSI and how the detectors would be removed. It has been shown that it is possible to split the structure and the focus is now on how best to remove the detectors. History has shown that a complex manipulator is required to remove detectors from a static array, hence an extra axis of movement for the support structure is being considered to ease the design of the extraction manipulator.





**Figure 4(f)5** Support Structure options proposed for GSI.

Two solutions are being discussed. Left: a 'tipping' solution. Right a rotary solution on the right.

A meeting of the Mechanical Working Group was held in November 2009 to highlight and discuss some of the above issues, further meetings are planned in December and January.

A preliminary specification for the array has been completed and issued to the Mechanical Working Group for comment, although it cannot yet be completed due to the number of outstanding issues.

**(iii) Activities during the next 6 months (Jan 2010 to June 2010)**

Test the parallel plate Mechanism.

Finalise the specification for the GSI phase.

Finalise the design work on the support structure prior to detailing parts.

(iv) Financial Statement: Work Package 6

Workpackage 6 Finance Summary (all figures in £k)

	Approved (excluding contingency) (1)	Actual spend in previous years (2)		Transfers (1a)	Current year 2009/10 (3)		Projected spend this year (4)	Latest estimate of future requirement (5)			Total		Variance		
		2008/09	for each FY		Actual Spend to end Sept 09 (3)	Projected spend this year (4)		2010/11	2011/12	2012/13	Actual spend (2+3) (6)	Projected Spend (2+4+5) (7)	Actual (6-1-1a)	Projected (7-1-1a)	
<b>University Staff Effort Costs*</b>															
Liverpool University Effort															
Manchester University Effort															
Surrey University Effort															
UWS Effort															
York University Effort															
University Sub-Total <sup>1</sup>															
<b>STFC Lab Costs</b>															
Daresbury	141.87	29.74			18.34	36.09		30.66	30.75	14.25	48.09	141.88		93.79	0.00
Daresbury Overheads	90.66	19.03			11.74	23.28		19.59	19.65	9.10	30.77	90.65		59.88	0.00
<b>STFC Lab Sub-Total</b>	<b>232.53</b>	<b>48.77</b>			<b>30.09</b>	<b>59.77</b>		<b>50.24</b>	<b>50.39</b>	<b>23.35</b>	<b>78.86</b>	<b>232.53</b>		<b>-153.67</b>	<b>0.00</b>
Equipment-STFC	80.85					0.00		42.55	8.51	29.79	0.00	80.85		-80.85	0.00
Travel STFC	12.27	1.96			1.47	2.03		4.60	2.96	0.71	3.43	12.27		-8.84	0.00
Travel Liverpool	1.85					0.49		0.84	0.48	0.04	0.00	1.85		-1.85	0.00
<b>Travel Total</b>	<b>14.12</b>	<b>1.96</b>			<b>1.47</b>	<b>2.52</b>		<b>5.45</b>	<b>3.44</b>	<b>0.76</b>	<b>3.43</b>	<b>14.13</b>		<b>-10.69</b>	<b>0.00</b>
Other Directly Allocated costs (eg consumables) Liverpool	27.44				7.43	6.65		13.75	7.04	0.00	7.43	27.44		-20.01	0.00
Liverpool University Estates costs															
Manchester University Estates costs															
Surrey University Estates costs															
UWS Estates costs															
York University Estates costs															
<b>University Estates costs total</b>															
Liverpool University indirect costs															
Manchester University indirect costs															
Surrey University indirect costs															
UWS indirect costs															
York University indirect costs															
<b>University indirect costs</b>															
<b>Total (excluding VAT and WA)</b>	<b>354.95</b>	<b>50.74</b>			<b>38.99</b>	<b>68.94</b>		<b>111.99</b>	<b>69.38</b>	<b>53.89</b>	<b>89.72</b>	<b>354.95</b>		<b>-265.23</b>	<b>0.00</b>
Working allowance															
VAT	14.15	0.00			0.00	0.00		7.45	1.49	5.21	0.00	14.15		-14.15	0.00
	17.50%														
	15.00%														
<b>Total (including VAT &amp; WA)</b>	<b>369.10</b>	<b>50.74</b>			<b>38.99</b>	<b>68.94</b>		<b>119.44</b>	<b>70.87</b>	<b>59.11</b>	<b>89.72</b>	<b>369.10</b>		<b>-279.38</b>	<b>0.00</b>
<b>Rolling Grant Effort</b>															
Liverpool Rolling Grant Effort	18.67				3.20	6.40		6.50	4.98	0.78	3.20	18.67		-15.47	0.00
Liverpool Rolling Grant Estates	5.04				0.87	1.74		1.78	1.32	0.21	0.87	5.05		-4.17	0.00
Liverpool Rolling Grant Indirect	17.01				2.93	5.86		5.99	4.47	0.70	2.93	17.02		-14.08	0.00
<b>Total Rolling Grant Cost</b>	<b>40.73</b>	<b>0.00</b>			<b>7.00</b>	<b>14.00</b>		<b>14.27</b>	<b>10.78</b>	<b>1.69</b>	<b>7.00</b>	<b>40.73</b>		<b>-33.73</b>	<b>0.00</b>
<b>Total (including VAT &amp; WA &amp; Rolling Grant)</b>	<b>409.82</b>	<b>50.74</b>			<b>45.99</b>	<b>82.94</b>		<b>133.71</b>	<b>81.65</b>	<b>60.79</b>	<b>96.72</b>	<b>409.82</b>		<b>-313.10</b>	<b>0.00</b>

Contingency (Held by STFC)

<sup>1</sup>Excluding workshop Allowance and VAT

\*The University staff effort recorded in this table should be the 80% amount STFC pays, including academic time

Use of columns:

- (1) = The amount approved by STFC
  - (1a) = This column should be used to show anyirements between headings, for example when Working Allowance is used, the amount should appear as a debit in the WA row and then credited to the relevant row
  - (2) = The actual spend in previous financial years, by year
  - (3) = The actual spend in the current financial year up to the most recent quarter
  - (4) = The total projected spend for the current financial year, including any expenditure so far (ie actual spend this year plus predictions of remaining spend this year)
  - (5) = Projected spend for the remaining years
  - (6) = The actual spend so far
  - (7) = Projected spend over the whole duration of the project (ie actual spend so far plus predictions of remaining spend to project completion)
- The variance columns show the difference between the actual and projected amounts and the approved amount.

(v) Resource Usage: Work Package 6

WP6								
NAME	INSTITUTE	% FTE 2008/09	% FTE 2009/10	% FTE 2010/11	% FTE 2011/12	% FTE 2012/13	Total Effort	Effort Remaining
J Strachan	Daresbury	0.222	0.240	0.233	0.207	0.058	0.960	0.498
R Griffiths	Daresbury	0.245	0.420	0.420	0.367	0.138	1.590	0.925
A Austin	Daresbury	0.000	0.047	0.033	0.047	0.033	0.160	0.113
Technician	Daresbury	0.000	0.099	0.071	0.099	0.071	0.340	0.241
D Seddon	Liverpool	0.085	0.150	0.150	0.105	0.020	0.510	0.275

(vi) Milestones: Work Package 6

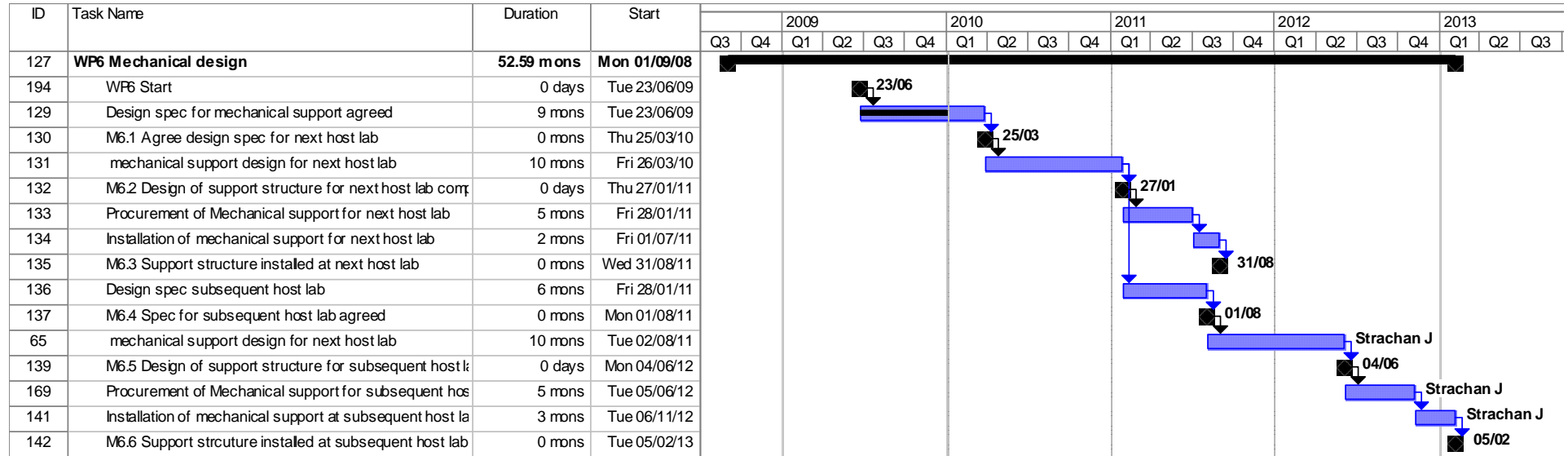
Milestone No.	Work Package	Milestone	Target Date	Status
M6.1	WP6	Agree design spec for next host lab	Mar 10	Delayed

Milestone No.	Work Package	Milestone	As at June 09	As at Sept 09	Delay due to		Affects Critical Path?	See Note
					UK?	Others?		
M6.1	WP6	Agree design spec for next host lab	22 Oct 09	Mar 10		Y	N	6.1
M6.2	WP6	Design of Support structure for next host lab complete	26 Aug 10	Jan 11		Y	N	6.1
M6.3	WP6	Support structure installed at next host lab	30 Mar 11	31 Aug 11		Y	N	6.1

M6.4	WP6	Agree design spec for subsequent host lab	28 Feb 11	01 Aug 11		Y	N	6.1
M6.5	WP6	Design of support structure for subsequent host lab complete	02 Jan 12	04 Jun 12		Y	N	6.1
M6.6	WP6	Support structure installed at subsequent host lab	04 Sep 12	05 Feb 13		Y	N	6.1

**6.1** End date of the Physics campaign at Legnaro has been pushed back, which has allowed more time to complete the specification and thus delays the program.

(vii) Gantt Chart: Work Package 6



(viii) Earned value Analysis: Work Package 6

ID	Task Name	Planned Value - PV (BCWS)	Earned Value - EV (BCWP)	AC (ACWP)	SPI	SV	CPI	CV	EAC	BAC	VAC
1	<b>WP6 Mechanical design</b>	<b>£34,904.15</b>	<b>£34,904.10</b>	<b>£34,904.15</b>	<b>1</b>	<b>-£0.04</b>	<b>1</b>	<b>-£0.04</b>	<b>£155,517.88</b>	<b>£155,517.69</b>	<b>-£0.19</b>
2	Phase 0 support	£24,331.93	£24,331.93	£24,331.93	1	£0.00	1	£0.00	£24,331.93	£24,331.93	£0.00
3	WP6 Start	£0.00	£0.00	£0.00	0	£0.00	0	£0.00	£0.00	£0.00	£0.00
4	Design spec for mechanical support agreed	£10,572.22	£10,572.18	£10,572.22	1	-£0.04	1	-£0.04	£41,045.09	£41,044.92	-£0.17
5	M6.1 Agree design spec for next host lab	£0.00	£0.00	£0.00	0	£0.00	0	£0.00	£0.00	£0.00	£0.00
6	mechanical support design for next host lab	£0.00	£0.00	£0.00	0	£0.00	0	£0.00	£829.19	£829.19	£0.00
7	mechanical support design for next host lab	£0.00	£0.00	£0.00	0	£0.00	0	£0.00	£34,462.89	£34,462.89	£0.00
8	M6.2 Design of support structure for next host lab c	£0.00	£0.00	£0.00	0	£0.00	0	£0.00	£0.00	£0.00	£0.00
9	Procurement of Mechanical support for next host lab	£0.00	£0.00	£0.00	0	£0.00	0	£0.00	£4,901.29	£4,901.29	£0.00
10	Procurement of Mechanical support for next host lab	£0.00	£0.00	£0.00	0	£0.00	0	£0.00	£7,643.29	£7,643.29	£0.00
11	Installation of mechanical support for next host lab	£0.00	£0.00	£0.00	0	£0.00	0	£0.00	£4,261.49	£4,261.49	£0.00
12	M6.3 Support structure installed at next host lab	£0.00	£0.00	£0.00	0	£0.00	0	£0.00	£0.00	£0.00	£0.00
13	Design spec subsequent host lab	£0.00	£0.00	£0.00	0	£0.00	0	£0.00	£1,573.34	£1,573.34	£0.00
14	Design spec subsequent host lab	£0.00	£0.00	£0.00	0	£0.00	0	£0.00	£2,946.27	£2,946.27	£0.00
15	M6.4 Spec for subsequent host lab agreed	£0.00	£0.00	£0.00	0	£0.00	0	£0.00	£0.00	£0.00	£0.00
16	mechanical support design for subsequent host lab	£0.00	£0.00	£0.00	0	£0.00	0	£0.00	£27,035.70	£27,035.70	£0.00
17	mechanical support design for subsequent host lab	£0.00	£0.00	£0.00	0	£0.00	0	£0.00	£2,820.07	£2,820.07	£0.00
18	M6.5 Design of support structure for subsequent hos	£0.00	£0.00	£0.00	0	£0.00	0	£0.00	£0.00	£0.00	£0.00
19	Procurement of Mechanical support for subsequent l	£0.00	£0.00	£0.00	0	£0.00	0	£0.00	£1,222.44	£1,222.44	£0.00
20	Installation of mechanical support at subsequent hos	£0.00	£0.00	£0.00	0	£0.00	0	£0.00	£2,444.88	£2,444.88	£0.00
21	M6.6 Support structure installed at subsequent host	£0.00	£0.00	£0.00	0	£0.00	0	£0.00	£0.00	£0.00	£0.00

4(g)            Work Package 7            **Project management**

**Leader:**            Prof. P. J. Nolan (Liverpool)

**Institutes:**        Liverpool and STFC Daresbury Laboratory

**(i)        Description of the work package**

AGATA is a large international collaboration consisting of over 40 European institutes in 10 countries. The collaboration has a well-organised management structure which is defined by a Memorandum of Understanding (MoU) signed by all of those involved. The UK will play its role in this management.

The AGATA management will have the following committees:

- The *AGATA Collaboration Council* (ACC), representing the nuclear-physics community collaborating in the project.
- The *AGATA Steering Committee* (ASC), representing the AGATA resources (funding agencies), and responsible for the science policy of the collaboration and the project management.
- The *AGATA Management Board* (AMB), responsible for the execution of the project along the lines defined by the ASC.

The AGATA Collaboration Council will meet once per year and will be open to all collaborators. In addition there is a UK management structure which has a number of roles. These include: (i) the management of the project funded by the UK research council; (ii) liaison between all of those in the UK working on the project to ensure delivery of the UK responsibilities; (iii) that the UK has an agreed policy; (iv) management of the UK part of any EU funding awarded to the project; and (v) the dissemination of information to the UK community concerning AGATA developments.

**(ii)        Activities during the past 6 months**

The ASC has met once: December 2009 at GSI, Germany. Prof. Paul Nolan is the Chair of the ASC, he holds this role for two years. In his role as ASC chair Prof Nolan has attended three meetings concerned with the siting of AGATA over the next 5 years. These meetings have involved Heads of funding agencies and Laboratory Directors.

The AMB, chaired by the Project Leader Prof John Simpson, has met twice. The minutes of these meetings provide an up-to-date record of the overall status of the project. Approved minutes are available at <http://npg.dl.ac.uk/AGATA/AMBMinutes/index.html>

The AMB has also held 4 phone conferences in-between the face-to-face meetings. The UK AGATA management committee has met twice in the past six months; September 2009 in Paisley and December 2009 in Manchester. The committee will continue to meet at three month intervals. Approved minutes are available at [http://npg.dl.ac.uk/AGATA/UK\\_Management/index.html](http://npg.dl.ac.uk/AGATA/UK_Management/index.html)

A second UK project meeting was held in November in Liverpool, all UK participants in the project were invited including the PDRAs and research students. The talks from the meeting are available from [http://npg.dl.ac.uk/NPG/Meetings/UK\\_AGATA\\_Meeting\\_Mar09/](http://npg.dl.ac.uk/NPG/Meetings/UK_AGATA_Meeting_Mar09/)

**(iii) Activities during the next 6 months**

The committees of the international AGATA project will continue to meet. The first AGATA Collaboration Council meeting is expected to take place. The AGATA Inauguration will take place in Legnaro. Regular, quarterly, meetings of the UK Management Committee will continue.

(iv) Financial Statement: Work Package 7

Workpackage 7 Finance Summary (all figures in £k)												
	Approved (excluding contingency) (1)	Actual spend in previous years (2)		Current year 2009/10		Latest estimate of future requirement (5)			Total		Variance	
		2008/09	for each FY	Actual Spend to end Sept 09 (3)	Projected spend this year (4)	2010/11	2011/12	2012/13	Actual spend (2+3) (6)	Projected spend (2+4+5) (7)	Actual (6-1-1a)	Projected (7-1-1a)
Transfers (1a)												
<b>University Staff Effort Costs*</b>	56.59			6.77	13.53	13.62	14.02	7.19	15.00	56.59	-41.59	0.00
Liverpool University Effort		8.23										
Manchester University Effort												
Surrey University Effort												
UWS Effort												
York University Effort												
<b>University Sub-Total<sup>1</sup></b>	<b>56.59</b>	<b>8.23</b>		<b>6.77</b>	<b>13.53</b>	<b>13.62</b>	<b>14.02</b>	<b>7.19</b>	<b>15.00</b>	<b>56.59</b>	<b>-41.59</b>	<b>0.00</b>
<b>STFC Lab Costs</b>	<b>155.46</b>	<b>14.24</b>		<b>20.64</b>	<b>40.17</b>	<b>41.26</b>	<b>41.92</b>	<b>17.86</b>	<b>34.89</b>	<b>155.46</b>	<b>-120.57</b>	<b>0.00</b>
Daresbury		6.78		11.15	21.48	23.06	23.49	9.77	17.93	84.58	-66.65	0.00
Daresbury Overheads												
<b>STFC Lab Sub-Total</b>	<b>240.04</b>	<b>21.02</b>		<b>31.79</b>	<b>61.66</b>	<b>64.32</b>	<b>65.41</b>	<b>27.63</b>	<b>52.81</b>	<b>240.04</b>	<b>-187.22</b>	<b>0.00</b>
Equipment <sup>1</sup>												
Travel Liverpool	9.77	1.43		2.95	1.70	3.21	2.51	0.93	4.37	9.78	-5.40	0.00
Travel STFC	21.44	3.62		2.98	4.56	5.36	5.52	2.38	6.59	21.44	-14.85	0.00
<b>Travel Total</b>	<b>31.22</b>	<b>5.05</b>		<b>5.92</b>	<b>6.26</b>	<b>8.57</b>	<b>8.03</b>	<b>3.31</b>	<b>10.97</b>	<b>31.22</b>	<b>-20.25</b>	<b>0.00</b>
Other Directly Allocated costs (eg consumables)												
Liverpool University Estates costs	7.19	1.09		0.70	1.74	1.71	1.75	0.90	1.78	7.18	-5.40	0.00
Manchester University Estates costs												
Surrey University Estates costs												
UWS Estates costs												
York University Estates costs												
<b>University Estates costs total</b>	<b>7.19</b>	<b>1.09</b>		<b>0.70</b>	<b>1.74</b>	<b>1.71</b>	<b>1.75</b>	<b>0.90</b>	<b>1.78</b>	<b>7.18</b>	<b>-5.40</b>	<b>0.00</b>
Liverpool University Indirect costs	24.24	3.67		2.93	5.86	5.75	5.92	3.04	6.60	24.25	-17.64	0.00
Manchester University Indirect costs												
Surrey University Indirect costs												
UWS Indirect costs												
York University Indirect costs												
<b>University Indirect costs</b>	<b>24.24</b>	<b>3.67</b>		<b>2.93</b>	<b>5.86</b>	<b>5.75</b>	<b>5.92</b>	<b>3.04</b>	<b>6.60</b>	<b>24.25</b>	<b>-17.64</b>	<b>0.00</b>
<b>Total (Excluding VAT and WA)</b>	<b>359.27</b>	<b>39.06</b>		<b>48.10</b>	<b>89.04</b>	<b>93.97</b>	<b>95.13</b>	<b>42.07</b>	<b>87.17</b>	<b>359.27</b>	<b>-272.11</b>	<b>0.00</b>
Working allowance												
VAT												
<b>Total (including VAT &amp; WA)</b>	<b>359.27</b>	<b>39.06</b>		<b>48.10</b>	<b>89.04</b>	<b>93.97</b>	<b>95.13</b>	<b>42.07</b>	<b>87.17</b>	<b>359.27</b>	<b>-272.11</b>	<b>0.00</b>

Contingency (held by STFC)

<sup>1</sup> Excluding workshop Allowance and VAT

\* The University staff effort recorded in this table should be the 80% amount STFC pays, including academic time

Use of columns:

- (1) = The amount approved by STFC
  - (1a) = This column should be used to show any virements between headings, for example when Working Allowance is used, the amount should appear as a debit in the WA row and then credited to the relevant row
  - (2) = The actual spend in previous financial years, by year
  - (3) = The actual spend in the current financial year up to the most recent quarter
  - (4) = The total projected spend for the current financial year, including any expenditure so far (ie actual spend this year plus predictions of remaining spend this year)
  - (5) = Projected spend for the remaining years
  - (6) = The actual spend so far
  - (7) = Projected spend over the whole duration of the project (ie actual spend so far plus predictions of remaining spend to project completion)
- The variance columns show the difference between the actual and projected amounts and the approved amount.



(v) Resource Usage: Work Package 7

WP7								
NAME	INSTITUTE	% FTE 2008/09	% FTE 2009/10	% FTE 2010/11	% FTE 2011/12	% FTE 2012/13	Total Effort	Effort Remaining
J Simpson	Daresbury	0.110	0.189	0.189	0.189	0.079	0.756	0.457
M Cordwell	Daresbury	0.292	0.500	0.500	0.500	0.208	2.000	1.208
P Nolan	Liverpool	0.090	0.180	0.180	0.180	0.090	0.720	0.450

(vi) Milestones: Work Package 7

**Table 1: Milestones achieved in the last six months**

Milestone No.	Work Package	Milestone	Target Date	Status
M7.6	WP7	4 <sup>th</sup> Meeting of UK Management group	June09	Complete
M7.7	WP7	5 <sup>th</sup> Meeting of UK Management group	Sep 09	Complete

**Table 2: Milestones due in the next six months**

Milestone no.	Work Package	Milestone	Target Date	Status
M7.8	WP7	6 <sup>th</sup> Meeting of UK Management group	Dec 09	Complete

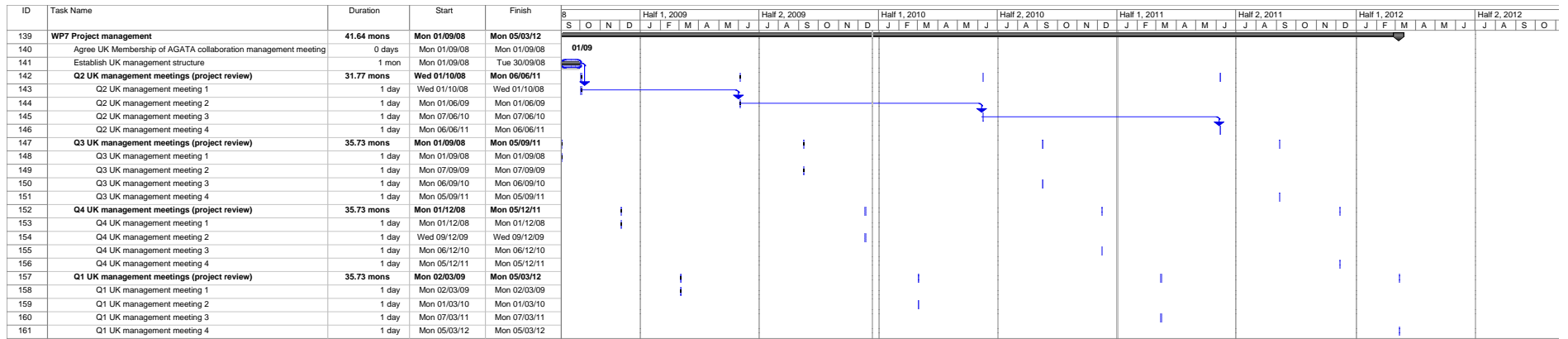
**Table 3: Overall Milestone List**

Milestone No.	Work Package	Milestone	As at June 09	As at Sept 09	Delay due to		Affects Critical Path?	See Note
					UK?	Others?		
M7.1	WP7	Agree UK Membership of AGATA collaboration meeting	1 Sept 08	1 Sept 08				Complete

M7.2	WP7	Establish UK management structure	30 Sept 08	30 Sept 08				Complete
M7.3	WP7	1 <sup>st</sup> Meeting of UK Management group	Nov 08	Nov 08				Complete
M7.4	WP7	2 <sup>nd</sup> Meeting of UK Management group	Jan 09	Jan 09				Complete
M7.5	WP7	3 <sup>rd</sup> Meeting of UK Management group	March 09	March 09				Complete
M7.6	WP7	4 <sup>th</sup> Meeting of UK Management group	June 09	June 09				Complete
M7.7	WP7	5 <sup>th</sup> Meeting of UK Management group	Sep 09	Sep 09				Complete
M7.8	WP7	6 <sup>th</sup> Meeting of UK Management group	Dec 09	Dec 09				Complete
M7.9	WP7	7 <sup>th</sup> Meeting of UK Management group	March 10	March 10				
M7.10	WP7	8 <sup>th</sup> Meeting of UK Management group	June 10	June 10				
M7.11	WP7	9 <sup>th</sup> Meeting of UK Management	Sep 10	Sep 10				

		group						
M7.12	WP7	10 <sup>th</sup> Meeting of UK Management group	Jan11	Jan11				
M7.13	WP7	11 <sup>th</sup> Meeting of UK Management group	March 11	March 11				
M7.14	WP7	12 <sup>th</sup> Meeting of UK Management group	June 11	June 11				
M7.15	WP7	13 <sup>th</sup> Meeting of UK Management group	Sep 11	Sep 11				
M7.16	WP7	14 <sup>th</sup> Meeting of UK Management group	Jan 12	Jan 12				
M7.17	WP7	15 <sup>th</sup> Meeting of UK Management group	March 12	March 12				
M7.18	WP7	16 <sup>th</sup> Meeting of UK Management group	June 12	June 12				

(viii) Gantt Chart: Work Package 7



4(h)                      Work Package 8                      **Equipment procurement and running costs**

**Leader:**                      Prof. P. J. Nolan (Liverpool)

**Institutes:**                      Liverpool and STFC Daresbury Laboratory

**(i)                      Description of the work package**

In its first phase, AGATA has developed all of the equipment (detectors and electronics etc.) needed for the project. During this phase, the UK funded ~20% of the capital spend of £5M, this is equivalent to approximately three detector capsules and associated equipment including development costs. In the present grant the UK will fund three detector capsules and associated equipment plus running costs. The spend can be divided into three areas: (i) detector capsules, cryostats and cables; (ii) electronics; and (iii) running costs. There needs to be close co-operation with the AGATA community on the details of what is purchased and the timing.

**(ii)                      Activities during the past 6 months**

Three detector capsules were ordered from *Canberra France* in March 2009. Delivery is expected to start in August 2010. The first two payments have been made on schedule and the work is progressing well. The specification of the triple cryostat, for these detector capsules, has been finalised and the order split into three parts. This is to allow cryostats to be made, at a discounted price, for two or three members of the collaboration at the same time. The order for the first part was placed in November 2009 (items were delivered in December 2009), the second part of the order is expected to be placed early in 2010. The final part of the order, the assembly of the crystals into the cryostat, will be placed in about one year.

The *AGATA Management Board* and *AGATA Steering Committee* have decided to build seven more digitisers of the current design to satisfy the needs of the Legnaro phase (up to mid 2011). A tender exercise is under way for these items. An order will follow. A review will then decide the best way forward for the new electronics needs for the operation at GSI with an increased number of detectors e.

The *AGATA Steering Committee (ASC)* and *AGATA Management Board* have agreed the running costs and their split for the next few years. The running costs will be reviewed annually at the ASC meeting towards the end of each year. In 2009 the budget for AGATA running has been agreed by the ASC, the UK agreed to contribute 20.5k€ in 2009. These funds have been used by Daresbury Laboratory and the University of Liverpool for a range of items including, shipping costs, mechanical repairs, parts, and consumables for the detector laboratory. In November 2009 the ASC received a report for the 2009 running costs which showed the budget was sufficient for 2009. At the same meeting the ASC agreed the running cost budget for 2010 including a UK contribution of 22.6k€. The UK contribution to running costs for 2011 and 2012 from the grant award will be 28.4k€ and 21.1k€.

**(iii)                      Activities during the next 6 months**

There are no milestones relating to equipment during this period. Progress on the detectors, cryostat and electronics will be monitored. The next running cost payment is expected to be made in this period.

(iv) Financial Statement: Work Package 8

Workpackage 8 Finance Summary (all figures in £k)

	Approved (excluding contingency) (1)	Transfers (1a)	Actual spend in previous years (2)		Current year 2009/10			Latest estimate of future requirement (5)			Total		Variance		
			2008/09	for each FY	Actual Spend to end Sept 09 (3)	Projected spend this year (4)	2010/11	2011/12	2012/13	Actual spend (2+3) (6)	Projected spend (2+4+5) (7)	Actual (6-1-1a)	Projected (7-1-1a)		
<b>University Staff Effort Costs*</b>															
Liverpool University Effort															
Manchester University Effort															
Surrey University Effort															
UWS Effort															
York University Effort															
University Sub-Total <sup>1</sup>															
<b>STFC Lab Costs</b>															
Daresbury															
<b>STFC Lab Sub-Total</b>															
Equipment <sup>2</sup> STFC	234.89			0.00	13.28	19.57	118.30	96.17	13.28	234.04					-0.85
Equipment <sup>3</sup> Liverpool	392.34	136.17		0.00	227.65	387.32	141.19	0.00	227.65	528.51					0.00
Equipment <sup>4</sup> Total	627.23	136.17		0.00	240.92	406.89	259.49	96.17	240.92	762.55					-0.85
Travel															0.00
Other Directly Allocated costs (eg consumables) STFC	72.72			5.50	12.16	14.20	19.03	23.33	10.66	72.72					0.00
Liverpool University Estates costs															
Manchester University Estates costs															
Surrey University Estates costs															
UWS Estates costs															
York University Estates costs															
<b>University Estates costs total</b>															
Liverpool University Indirect costs															
Manchester University Indirect costs															
Surrey University Indirect costs															
UWS Indirect costs															
York University Indirect costs															
<b>University Indirect costs</b>															
<b>Total (Excluding VAT and WA)</b>	699.96	136.17		5.50	253.08	421.09	278.52	119.50	10.66	258.58	835.27			-577.55	-0.85
Working allowance (ex VAT)	225.53	-136.17				22.34	22.34	22.34	0.00	0.00	89.36			-89.36	0.00
VAT	149.23			0.00	34.15	75.12	49.32	20.74	3.91	34.15	149.08			-115.09	-0.15
17.50%															
15.00%															
<b>Total (Including VAT &amp; WA)</b>	1074.72	0.00		5.50	287.23	518.55	350.18	162.58	36.90	292.73	1073.72			-781.99	-1.00

478.09

Committed funds  
Equipment Liverpool (detectors)

Contingency (Held by STFC)

<sup>1</sup> Excluding workshop Allowance and VAT

<sup>2</sup> The University staff effort recorded in this table should be the 80% amount STFC pays, including academic time

Use of columns:

- (1) = The amount approved by STFC
  - (1a) = This column should be used to show any virements between headings, for example when Working Allowance is used, the amount should appear as a debit in the WA row and then credited to the relevant row
  - (2) = The actual spend in previous financial years, by year
  - (3) = The actual spend in the current financial year up to the most recent quarter
  - (4) = The total projected spend for the current financial year, including any expenditure so far (ie actual spend this year plus predictions of remaining spend this year)
  - (5) = Projected spend for the remaining years
  - (6) = The actual spend so far
  - (7) = Projected spend over the whole duration of the project (ie actual spend so far plus predictions of remaining spend to project completion)
- The variance columns show the difference between the actual and projected amounts and the approved amount.

(v) Milestones: Work Package 8

<u>Milestone No.</u>	<u>Work Package</u>	<u>Milestone</u>	<u>Target Date</u>	<u>Status</u>
M8.4	WP8	First payment (20%) for detector capsules	4 May 09	Complete
M8.5	WP8	Order triple cryostat and digitiser modules	03 July 09	First part Cryostat Nov 09  Digitiser
M8.6	WP8	Make second payment for detector capsules	05 Oct 09	Complete

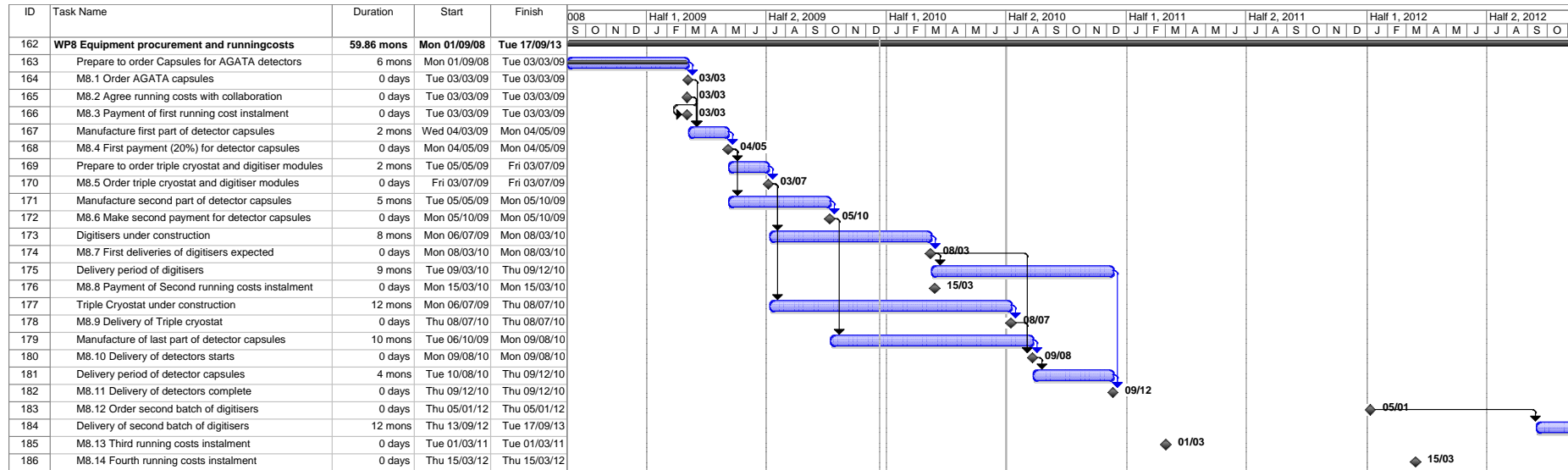
<u>Milestone no.</u>	<u>Work Package</u>	<u>Milestone</u>	<u>Target Date</u>	<u>Status</u>
M8.8	WP8	Payment of second running cost instalment	15 Mar 10	

<u>Mile-stone No.</u>	<u>Work Package</u>	<u>Milestone</u>	<u>As at June 09</u>	<u>As at Sept 09</u>	<u>Delay due to</u>		<u>Affects Critical Path?</u>	<u>See Note</u>
					<u>UK?</u>	<u>Others?</u>		
M8.1	WP8	Order AGATA detector capsules	3 March 09	3 March 09				Complete
M8.2	WP8	Agree running costs with collaboration	3 March 09	3 March 09				Complete
M8.3	WP8	Payment of first running cost instalment	3 March 09	3 March 09				Complete

M8.4	WP8	First payment (20%) for detector capsules	4 May 09	4 May 09				Complete
M8.5	WP8	Order triple cryostat and digitiser modules	3 July 09	Cryostat Nov09  Digitiser	Yes	Yes	No  No	Agreeing contract.  Agreeing with collaboration
M8.6	WP8	Make Second payment for detector capsules	5 Oct 09	31 Aug 09				Complete
M8.7	WP8	First deliveries of digitiser expected	8 Apr 10	8 Apr 10				
M8.8	WP8	Payment of second running cost instalment	15 Mar 10	15 Mar 10				
M8.9	WP8	Delivery of triple cryostat	8 July 10	8 July 10				
M8.10	WP8	Delivery of detectors starts	9 Aug 10	9 Aug 10				
M8.11	WP8	Delivery of detectors complete	10 Jan 11	10 Jan 11				
M8.12	WP8	Order second batch of digitisers	13 June 11	13 June 11				
M8.13	WP8	Third running costs instalment	1 Mar 11	1 Mar 11				
M8.14	WP8	Fourth running costs instalment	15 Mar 12	15 Mar 12				



(vi) Gantt Chart: Work Package 8



## 5 Financial Statement, Whole Project

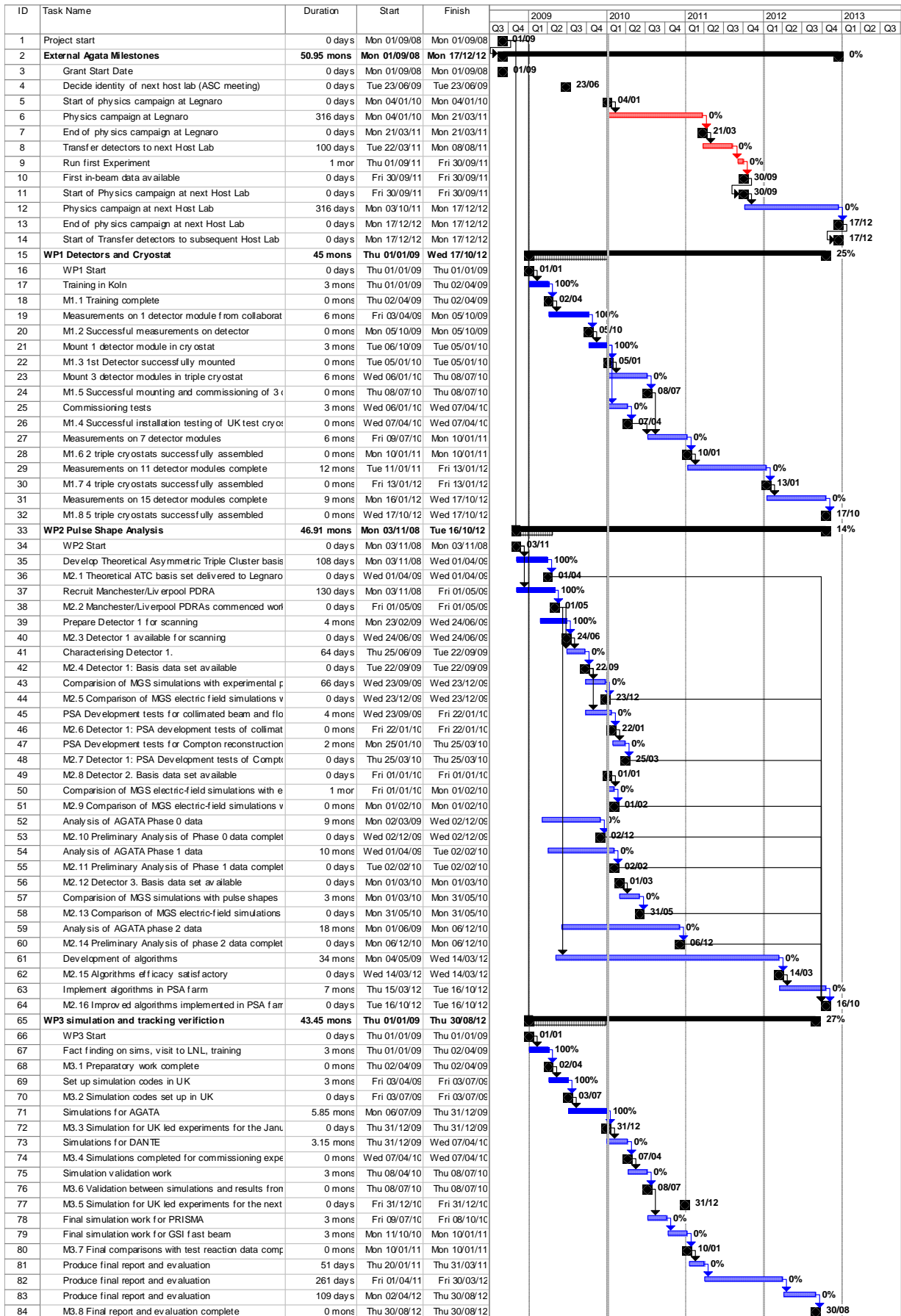
Finance Summary (all figures in £k)

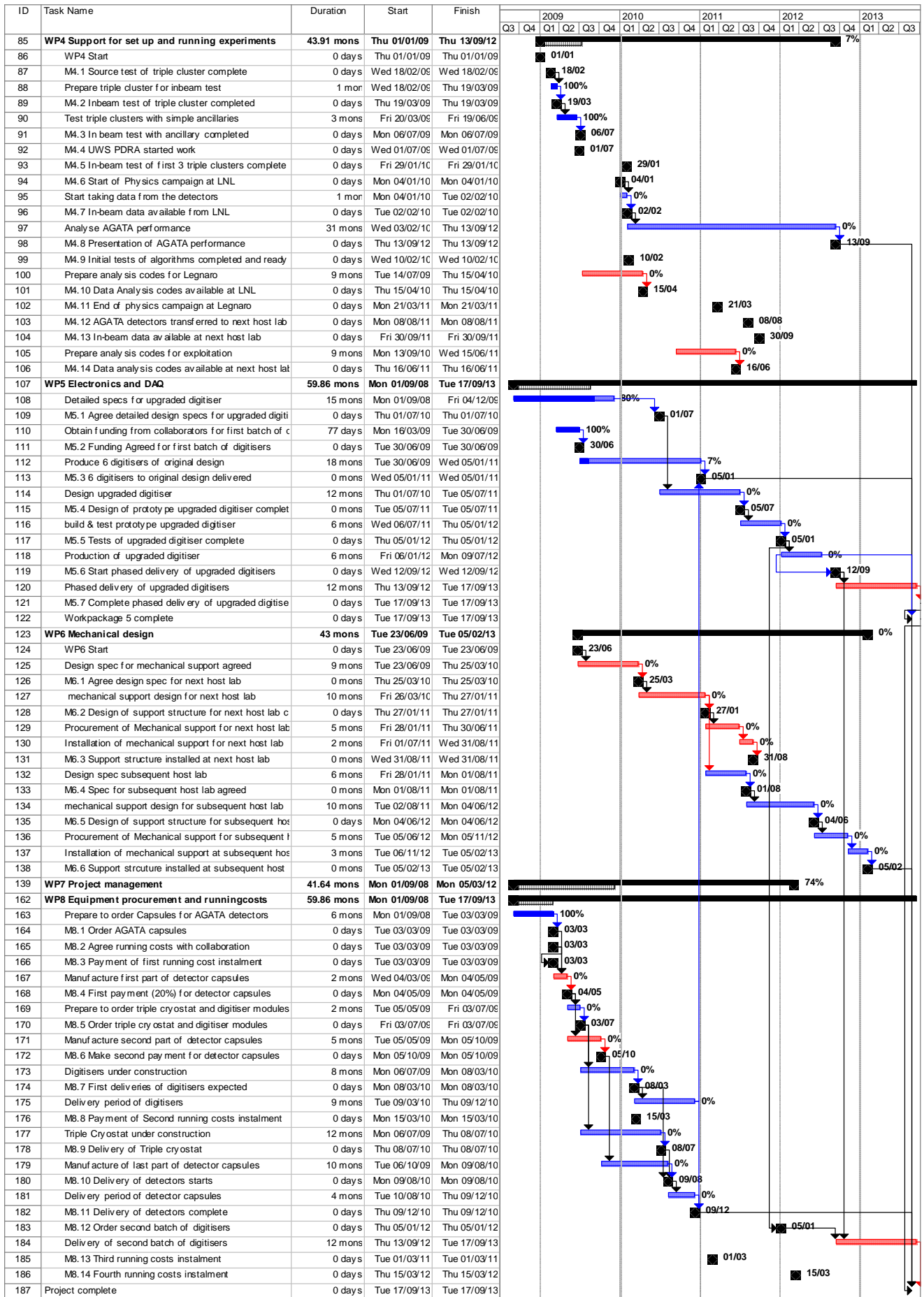
	Work Package totals (excluding contingency) (1)	Transfers (1a)	Actual spend in previous years (2)		Current year 2009/10		Latest estimate of future requirement (5)			Total		Variance		
			2008/09	for each FY	Actual Spend to end Sept 09 (3)	Projected spend this year (4)	2010/11	2011/12	2012/13	Actual spend (2+3) (6)	Projected spend (2+4+5) (7)	Actual (6-1-1a)	Projected (7-1-1a)	
<b>University Staff Effort Costs*</b>														
Liverpool University Effort	296.91		22.93		41.44	82.88	96.71	63.63	30.75	64.37	296.90	-232.53	0.00	
Manchester University Effort	83.50		1.64		7.88	34.32	38.29	7.52	1.73	9.52	83.50	-73.97	0.00	
Surrey University Effort	63.88		7.03		7.03	17.20	18.22	15.32	6.10	14.06	63.88	-49.81	0.00	
UWS Effort	88.52		1.37		9.43	28.13	38.74	16.31	3.98	10.80	88.52	-77.72	0.00	
York University Effort	117.33		14.89		14.75	34.08	36.37	21.14	10.84	29.64	117.33	-87.69	0.00	
<b>University Sub-Total<sup>1</sup></b>	<b>650.14</b>		<b>47.87</b>		<b>80.53</b>	<b>196.60</b>	<b>228.34</b>	<b>123.92</b>	<b>53.40</b>	<b>128.40</b>	<b>650.14</b>	<b>-521.74</b>	<b>0.00</b>	
<b>STFC Lab Costs</b>														
Daresbury	531.19		70.52		75.73	152.23	153.08	113.65	41.72	146.25	531.19	-384.94	0.00	
Daresbury Overheads	275.99		36.04		37.02	77.47	78.49	61.03	22.96	73.06	275.99	-202.93	0.00	
<b>STFC Lab Sub-Total</b>	<b>807.18</b>		<b>106.56</b>		<b>112.75</b>	<b>229.70</b>	<b>231.57</b>	<b>174.68</b>	<b>64.68</b>	<b>219.30</b>	<b>807.18</b>	<b>-587.87</b>	<b>0.00</b>	
Student Fees Liverpool	11.98		2.48		1.57	3.15	3.14	2.42	0.80	4.05	11.98	-7.93	0.00	
Student Fees Surrey	11.74		3.30		3.30	2.52	2.90	2.28	0.74	6.60	11.74	-5.14	0.00	
Student Fees York	11.74		2.20		0.00	1.37	2.76	2.86	1.46	2.20	10.64	-9.54	-1.10	
Equipment Liverpool	454.04	136.17	3.47		234.58	445.56	141.19	0.00	0.00	238.04	590.21	-352.17	0.00	
Equipment Manchester	20.00		3.90		1.24	16.10	0.00	0.00	0.00	5.14	20.00	-14.86	0.00	
Equipment Surrey	20.00		1.73		7.52	18.27	0.00	0.00	0.00	9.25	20.00	-10.75	0.00	
Equipment UWS	20.43		0.00		0.00	20.43	0.00	0.00	0.00	0.00	20.43	-20.43	0.00	
Equipment York	14.47		14.42		0.00	0.05	0.00	0.00	0.00	14.42	14.48	-0.04	0.01	
Equipment STFC	315.74		0.00		13.28	19.57	160.85	104.68	29.79	13.28	314.89	-302.47	-0.85	
<b>Equipment Total</b>	<b>844.68</b>	<b>136.17</b>	<b>23.52</b>		<b>256.62</b>	<b>519.98</b>	<b>302.04</b>	<b>104.68</b>	<b>29.79</b>	<b>280.14</b>	<b>980.01</b>	<b>-700.71</b>	<b>-0.84</b>	
Travel Liverpool	55.80		4.85		10.09	15.90	19.28	11.80	3.99	14.94	55.81	-40.86	0.00	
Travel Manchester	11.48		0.11		2.37	5.21	6.15	0.00	0.00	2.48	11.47	-8.99	0.00	
Travel Surrey	12.75		1.02		2.85	2.97	5.61	2.38	0.62	4.89	13.59	-7.86	0.85	
Travel UWS	15.28		0.36		2.81	6.00	8.91	0.00	0.00	3.17	15.27	-12.11	0.00	
Travel York	15.79		1.23		1.21	5.80	5.01	2.96	0.80	2.44	15.79	-13.35	0.00	
Travel STFC	69.76		10.53		5.76	16.77	21.21	16.06	5.18	16.29	69.76	-53.46	0.00	
<b>Travel Total</b>	<b>180.85</b>		<b>18.09</b>		<b>26.11</b>	<b>53.65</b>	<b>66.17</b>	<b>33.20</b>	<b>10.59</b>	<b>44.21</b>	<b>181.70</b>	<b>-136.64</b>	<b>0.85</b>	
Other Directly Allocated costs (eg consumables) Liverpool	67.96		0.00		13.73	17.87	31.08	18.27	0.75	13.73	67.97	-54.23	0.00	
Other Directly Allocated costs (eg consumables) STFC	108.85		10.74		17.40	22.81	28.10	32.60	14.60	28.14	108.85	-80.72	0.00	
<b>Other Directly Allocated costs (total)</b>	<b>176.81</b>		<b>10.74</b>		<b>31.13</b>	<b>40.68</b>	<b>59.18</b>	<b>50.87</b>	<b>15.35</b>	<b>41.87</b>	<b>176.82</b>	<b>-134.95</b>	<b>0.00</b>	
Liverpool University Estates costs	70.53		3.27		9.79	19.93	24.73	14.97	7.64	13.06	70.53	-57.47	0.00	
Manchester University Estates costs	30.54		3.18		1.91	10.26	14.22	2.48	0.40	5.09	30.53	-25.45	0.00	
Surrey University Estates costs	3.89		0.49		0.49	0.93	0.96	1.00	0.51	0.97	3.89	-2.91	0.00	
UWS Estates costs	18.19		1.14		2.27	5.58	7.57	3.22	0.69	3.41	18.19	-14.78	0.00	
York University Estates costs	23.78		2.97		2.97	9.97	8.16	1.76	0.92	5.95	23.78	-17.84	0.00	
<b>University Estates costs total</b>	<b>146.92</b>		<b>11.04</b>		<b>17.43</b>	<b>46.66</b>	<b>55.63</b>	<b>23.43</b>	<b>10.15</b>	<b>28.47</b>	<b>146.92</b>	<b>-118.44</b>	<b>0.01</b>	
Liverpool University Indirect costs	237.93		11.02		33.61	67.22	83.42	50.49	25.77	44.63	237.93	-193.30	0.00	
Manchester University Indirect costs	82.73		8.62		5.17	27.79	38.53	6.71	1.09	13.79	82.75	-68.96	0.00	
Surrey University Indirect costs	8.88		1.11		1.11	2.11	2.19	2.29	2.22	8.88	8.88	-6.66	0.00	
UWS Indirect costs	69.96		1.76		8.74	22.12	31.05	12.40	2.64	10.51	69.96	-59.45	0.00	
York University Indirect costs	47.09		5.89		19.70	16.02	16.02	3.63	1.86	11.77	47.08	-35.31	0.00	
<b>University Indirect costs</b>	<b>446.61</b>		<b>28.40</b>		<b>54.52</b>	<b>138.94</b>	<b>171.23</b>	<b>75.51</b>	<b>32.53</b>	<b>82.92</b>	<b>446.61</b>	<b>-363.68</b>	<b>0.00</b>	
<b>Total (Excluding VAT and WA)</b>	<b>3288.65</b>	<b>136.17</b>	<b>254.20</b>		<b>583.97</b>	<b>1233.24</b>	<b>1122.95</b>	<b>593.85</b>	<b>219.48</b>	<b>838.17</b>	<b>3423.73</b>	<b>-2586.64</b>	<b>-1.09</b>	
Working allowance (ex VAT)	225.53	-136.17				22.34	22.34	22.34	22.34	0	89.36	-89.36	0.00	
VAT	187.29		3.53	0.00	38.49	94.91	56.77			22.23	9.12	186.55	-145.27	-0.74
15.00%														
17.50%														
<b>Total (including VAT &amp; WA)</b>	<b>3701.47</b>	<b>0.00</b>	<b>257.73</b>	<b>0.00</b>	<b>622.46</b>	<b>1350.49</b>	<b>1202.06</b>	<b>638.42</b>	<b>250.94</b>	<b>880.19</b>	<b>3699.64</b>	<b>-2821.27</b>	<b>-1.82</b>	
<b>Rolling Grant Effort</b>														
Liverpool Rolling Grant Effort	91.58		10.70		13.37	26.74	26.24	20.62	7.28	24.07	91.58	-67.51	0.00	
Liverpool Rolling Grant Estates	26.09		3.63		3.71	7.42	7.48	5.62	1.94	7.34	26.10	-18.75	0.01	
Liverpool Rolling Grant Indirect	88.00		12.25		14.22	25.46	24.82	18.89	6.57	26.47	87.89	-61.53	-0.01	
<b>Total Rolling Grant Cost</b>	<b>205.66</b>		<b>26.58</b>		<b>31.30</b>	<b>59.63</b>	<b>58.55</b>	<b>45.13</b>	<b>15.79</b>	<b>57.88</b>	<b>205.67</b>	<b>-147.79</b>	<b>0.01</b>	
<b>Total (including VAT &amp; WA &amp; Rolling Grant)</b>	<b>3907.13</b>		<b>284.31</b>		<b>653.76</b>	<b>1410.12</b>	<b>1260.61</b>	<b>683.55</b>	<b>266.73</b>	<b>938.07</b>	<b>3905.31</b>	<b>-2969.06</b>	<b>-1.82</b>	

### **Use of the Working Allowance**

At the last meeting several potential uses of the Working Allowance were identified. The main one of these was for the purchase of the germanium detector crystals mainly due to a change in exchange rates. This is expected to be £160k. No further information is available since the last meeting. The cost of the next two items to be purchased (the triple cryostat and the first batch of electronics) will be known during the next six month period.

# 6 Overall Project Plan





## 7 Risk Register

Ref WP1	Cost	Risk Description	Potential Impact on Project	Inherent Risk Score			Existing Controls	Mitigating factors	Residual risk score			Comment	Risk owner	Risk closed date	Cost (£k)	Schedule Impact (Mons)	Contingency working allowance
				L	I	LxI			L	I	LxI						
1.1	£532k	Ge delivery	Delay of assembly	3	2	6	Retain money	Investigate second supplier	3	2	6		Nolan	04/12	0	6	0
1.2		Ge failure	Effort for re- testing	2	2	4	Realistic specification	Allow time in programme	2	1	2		H. Boston	04/12	0	7	0
1.3		Cryostat failure	Reassembly	2	2	4	Skilled staff	Allow time in programme	2	1	2		H. Boston	Retire	0	0	0

Ref WP2	Cost	Risk Description	Potential Impact on Project	Inherent Risk Score			Existing Controls	Mitigating factors	Residual risk score			Comment	Risk owner	Risk closed date	Cost (£k)	Schedule Impact (Mons)	Contingency working allowance
				L	I	LxI			L	I	LxI						
2.1	£352k	LN failure	Detector failure	1	2	2	Safety shutdown	Operating procedures and training	1	2	2		H.Boston	04/12	16	2	2

2.2	Electronics failure	No data collection	1	2	2	Use is a clean environment	Spare channels	1	2	2	Lazarus	04/12	20	3	2
2.3	Delay of beam time	Delay in in-beam test	1	2	2	Rescheduling	Negotiate priority beam time	1	2	2	AGATA project manager Simpson	Retire	0	0	0
2.4	Delay of components for demonstrator	No data to be analysed	3	2	6	Regular review	Reschedule availability of parts and allow time in programme	2	2	4	AGATA project manager Simpson	Retire	0	0	0
2.5	PS Analysis skills deficient	No personnel to analyse data	2	2	4	Ensure wide advertising of positions	Re-advertise or approach suitable candidates	1	2	2	University PI's	Retire	0	0	0
2.6	Failure of detector Pre Amps	Delay as there are currently no spares	3	2	6	Skilled Staff	Procure spare PreAmps	3	1	3	H Boston	04/09	2	2	0

Ref WP3	Cost	Risk Description	Potential Impact on Project	Inherent Risk Score			Existing Controls	Mitigating factors	Residual risk score			Comment	Risk owner	Risk closed date	Cost (£k)	Schedule Impact (Mons)	Contingency working allowance
				L	I	LxI			L	I	LxI						
3.1	£698k	Availability of nuclear physicists with necessary skills	Delay in modelling and data analysis	1	2	2	Tailored adverts widely circulated	Re-advertise position or approach suitable candidates	1	2	2		University PI's	04/12	10	4	1.5
3.2		Delay in data from WP2 for verification	Delay in verification of simulated and real data	2	3	6	Continuation of simulations	Close liaison with WP2	1	3	3		AGATA project manager Simpson	07/10	0	3	0

Ref WP4	Cost	Risk Description	Potential Impact on Project	Inherent Risk Score			Existing Controls	Mitigating factors	Residual risk score			Comment	Risk owner	Risk closed date	Cost (£k)	Schedule Impact (Mons)	Contingency working allowance
				L	I	LxI			L	I	LxI						
4.1	£1366k	Manpower availability	Delay in work	1	2	2	Make a plan	Arrange well in advance	1	2	1		Nolan	04/12	10	4	1.5



4.2		Availability of experts from AGATA community	Delay in work	2	3	6	Agree schedule	Make project plan well in advance	1	3	3		AGATA project manager Simpson	04/12	0	6	0
4.3		Beam delivery failure	Delay in data collection and analysis	1	3	3	Liaise with host laboratory	Negotiate priority beam time	1	2	2		Host laboratory	04/12	4	3	1
4.4		Laboratory infrastructure	No beam and/or failure of detectors	1	2	2	Appoint host laboratory coordinator	Make a plan with host laboratory	1	1	1		Host laboratory	04/12	4	3	1

Ref WP5	Cost	Risk Description	Potential Impact on Project	Inherent Risk Score			Existing Controls	Mitigating factors	Residual risk score			Comment	Risk owner	Risk closed date	Cost (£k)	Schedule Impact (Mons)	Contingency working allowance
				L	I	LxI			L	I	LxI						
5.5	£429k	Sourcing digitiser components	Delay in completion	2	2	4	Be aware of the situation	Procure as early as possible	1	2	2		Lazarus	12/11	0	3	0
5.6		Obsolete electronics	Delay in completion	3	2	6	Procure as early as possible	Investigate specialist broker for supply	2	2	4		Lazarus	12/11	5	3	1.5

5.7		Delay in recruitment of VHDL expert	Significant delay in the electronics	3	3	9	Plan use of this expertise in advance	Investigate availability of additional expertise in the collaboration	3	3	9	Lazarus	retire	0	0	0
5.8		Unable to fill VHDL post	Significant delay in the electronics	1	3	3	Recruit as early as possible	Investigate availability of additional expertise in the collaboration	1	3	3	Lazarus	retire	0	0	0
5.9		Unable to fill VHDL post or find effort in the collaboration	Significant delay in the electronics	1	3	3	Investigate availability of additional expertise in the collaboration	Use contractor	1	3	3	Lazarus	retire	0	0	0
5.10		Unable to retain VHDL effort from Technology dep't	Significant delay in the electronics	1	3	3	Ensure TD understand AGATA's need for VHDL effort and plan it in forecasts	Good working relationship with TD	1	3	3	Lazarus	9/12	0	6	0



		ineffective	inefficiently run				meeting take place as scheduled to monitor all aspects of the project	leaders									
7.2		Collaboration breakdown	Insufficient expertise or resources for the project	1	1	1	Regular management meetings	Look for new collaborators	1	1	1		AGATA Steering committee	04/12	0	12	0
7.3		Countries not being able to secure their funding	Efficiency and effectiveness drops	2	2	4	Revise plan in light of resources	Agree physics priority in line with resources available	2	2	4		AGATA Steering committee	04/11	0	12	0

Ref WP8	Cost	Risk Description	Potential Impact on Project	Inherent Risk Score			Existing Controls	Mitigating factors	Residual risk score			Comment	Risk owner	Risk closed date	Cost (£k)	Schedule Impact (Mons)	Contingency working allowance
				L	I	LxI			L	I	LxI						
8.1	£2278k	Under estimation running costs	Insufficient funds for operation of AGATA	2	2	4	Plan based on past experience	Review regularly, keep contingency	2	2	4		Nolan	04/12	40	0	12

8.2		Failure of Ge detectors out of warranty	Efficiency and effectiveness drops	1	3	3	Only allow detectors to be handled by experts	Ensure well trained staff	1	3	3	Paid by collaboration	AGATA project manager Simpson	Retire	0	0	0
8.3		Increase in raw Ge costs	Insufficient funds	2	2	4	Place orders as soon as possible	Investigate alternative suppliers	2	2	4		AGATA project manager Simpson	Retire	0	0	0
8.4		Failure of electronics	Efficiency and effectiveness drops	2	3	6	Purchase additional electronics	Use additional electronics	2	3	6	Awarded pro rata with digitiser-30Kx11	Nolan	04/12	333	9	33
8.5		Only one Ge supplier	Price increase and delay from manufacturer	3	4	12	Place orders well in advance, obtain fixed price quote	Encourage alternative supplier	3	4	12		Nolan	Retire	0	0	0
8.6		Computing and PSA	Insufficient for effective operation	2	3	6	Monitor computing power as AGATA builds	Plan for additional computing power if	1	3	6		Nolan	Retire	0	0	0

							up	needed										
--	--	--	--	--	--	--	----	--------	--	--	--	--	--	--	--	--	--	--

## New/Retired Risks

Ref WP1	Cost	Risk Description	Potential Impact on Project	Inherent Risk Score			Existing Controls	Mitigating factors	Residual risk score			Comment	Risk owner	Risk close d date	Cost (£k)	Schedule Impact (Mons)	Contingency working allowance
				L	I	LxI			L	I	LxI						
1.3		Cryostat failure	Reassembly	2	2	4	Skilled staff	Allow time in programme	2	1	2		H. Boston	Retire	0	0	0

Ref WP2	Cost	Risk Description	Potential Impact on Project	Inherent Risk Score			Existing Controls	Mitigating factors	Residual risk score			Comment	Risk owner	Risk closed date	Cost (£k)	Schedule Impact (Mons)	Contingency working allowance
				L	I	LxI			L	I	LxI						
2.3		Delay of beam time	Delay in in-beam test	1	2	2	Rescheduling	Negotiate priority beam time	1	2	2		AGATA project manager Simpson	Retire	0	0	0
2.4		Delay of components for demonstrator	No data to be analysed	3	2	6	Regular review	Reschedule availability of parts and allow time in programme	2	2	4		AGATA project manager Simpson	Retire	0	0	0

2.5		PS Analysis skills deficient	No personnel to analyse data	2	2	4	Ensure wide advertising of positions	Re-advertise or approach suitable candidates	1	2	2		University PI's	Retire	0	0	0
-----	--	------------------------------	------------------------------	---	---	---	--------------------------------------	--	---	---	---	--	-----------------	--------	---	---	---

Ref WP5	Cost	Risk Description	Potential Impact on Project	Inherent Risk Score			Existing Controls	Mitigating factors	Residual risk score			Comment	Risk owner	Risk closed date	Cost (£k)	Schedule Impact (Mons)	Contingency working allowance
				L	I	LxI			L	I	LxI						
5.7		Delay in recruitment of VHDL expert	Significant delay in the electronics	3	3	9	Plan use of this expertise in advance	Investigate availability of additional expertise in the collaboration	3	3	9		Lazarus	retire	0	0	0
5.8		Unable to fill VHDL post	Significant delay in the electronics	1	3	3	Recruit as early as possible	Investigate availability of additional expertise in the collaboration	1	3	3		Lazarus	retire	0	0	0
5.9		Unable to fill VHDL post or	Significant delay in the	1	3	3	Investigate availability of	Use	1	3	3		Lazarus	retire	0	0	0



5.10		find effort in the collaboration  Unable to retain VHDL effort from Technology dep't	electronics  Significant delay in the electronics	1	3	3	additional expertise in the collaboration  Ensure TD understand AGATA's need for VHDL effort and plan it in forecasts	contractor  Good working relationship with TD	1	3	3		Lazarus	9/12	0	6	0
------	--	--	---	---	---	---	---	---	---	---	---	--	---------	------	---	---	---

Ref WP8	Cost	Risk Description	Potential Impact on Project	Inherent Risk Score			Existing Controls	Mitigating factors	Residual risk score			Comment	Risk owner	Risk closed date	Cost (£k)	Schedule Impact (Mons)	Contingency working allowance
				L	I	LxI			L	I	LxI						
8.2		Failure of Ge detectors out of warranty	Efficiency and effectiveness drops	1	3	3	Only allow detectors to be handled by experts	Ensure well trained staff	1	3	3	Paid by collaboration	AGATA project manager Simpson	Retire	0	0	0

8.3		Increase in raw Ge costs	Insufficient funds	2	2	4	Place orders as soon as possible	Investigate alternative suppliers	2	2	4		AGATA project manager Simpson	Retire	0	0	0
8.5		Only one Ge supplier	Price increase and delay from manufacturer	3	4	12	Place orders well in advance, obtain fixed price quote	Encourage alternative supplier	3	4	12		Nolan	Retire	0	0	0
8.6		Computing and PSA	Insufficient for effective operation	2	3	6	Monitor computing power as AGATA builds up	Plan for additional computing power if needed	1	3	6		Nolan	Retire	0	0	0

## 8 UK AGATA Publications

1. *Validation of Pulse Shape Simulations for an AGATA prototype detector*  
M. R. Dimmock, A.J. Boston, J.R. Cresswell, I. Lazarus, P. Medina, P. Nolan, C. Parisel, C. Santos, J. Simpson and C. Unsworth  
IEEE TNS 56 No.4 (2009) 2415
2. *Characterisation results from an AGATA prototype detector*  
M. Dimmock, A.J. Boston, H.C. Boston, J.R. Cresswell, L. Nelson, P.J. Nolan, C. Unsworth, I. Lazarus and J. Simpson  
IEEE TNS 56 No.3 (2009) 1593
3. *Performance of an AGATA asymmetric detector*  
A.J. Boston, M.R. Dimmock, C. Unsworth, H.C. Boston, R.J. Cooper, A.N. Grint, L.J. Harkness, I.H. Lazarus, M. Jones, P.J. Nolan, D.C. Oxley, J. Simpson, M. Slee and the AGATA collaboration  
Nuclear Instruments and Methods in Physics Research A604 (2009) 48
4. *From Ge(Li) Detectors to Gamma-Ray Tracking Arrays: 50 Years of Gamma-Spectroscopy with Germanium Detectors*  
J. Eberth and J.Simpson.  
Progress in Particle and Nuclear Physics 60 (2008) 283
5. *Position resolution of the prototype AGATA triple-cluster detector from an in-beam experiment*  
F.Recchia,, D.Bazzacco, E.Farnea , A.Gadea, R.Venturelli, T.Beck, P.Bednarczyk, A.Buerger, A.Dewald, M.Dimmock, G.Duchene , J.Eberth, T.Faul, J.Gerl, R.Gernhaeuser, K. Hauschild, A.Holler, P.Jones, W.Korten, Th.Kroll , R.Krucken, N.Kurz, J.Ljungvall, S. Lunardi, P.Maierbeck, D.Mengoni, J.Nyberg, L.Nelson, G.Pascovici, P.Reiter, H.Schaffner, M. Schlarb, T.Steinhardt, O.Thelen, C.A.Ur, J.J.Valiente-Dobon, D.Weisshaar  
Nuclear Instruments and Methods in Physics Research A 604 (2009) 555–562
6. *Status and Performance of an AGATA asymmetric detector*  
A.J. Boston, M.R. Dimmock, C. Unsworth, H.C. Boston, R.J. Cooper, A.N. Grint, L.J. Harkness, I.H. Lazarus, M. Jones, P.J. Nolan, D.C. Oxley, J. Simpson, and M. Slee,  
AIP Conf. Proc., Volume 1109, pp. 38-43  
NUCLEAR PHYSICS AND APPLICATIONS: Proceedings of the First Ulaanbaatar Conference on Nuclear Physics and Applications (2009). doi:10.1063/1.3122257

